

Nanomedicine & Nanotechnology Open Access

Real Cathode and Anode of Internal DC Electric Circuit in FL Lamp

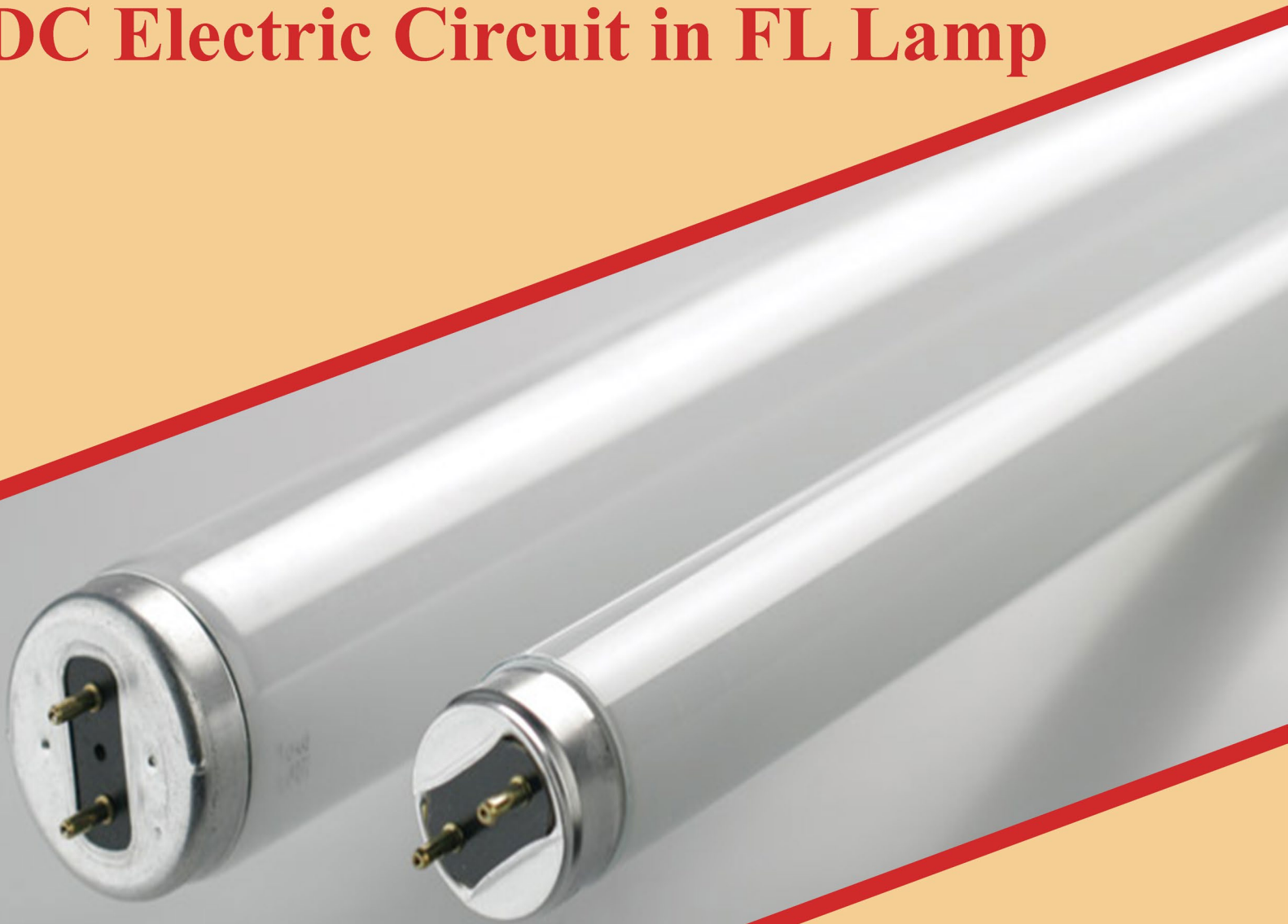

Lyuji Ozawa

**Published by
Medwin Publishers LLC**

copyright© Lyuji Ozawa.

Nanomedicine & Nanotechnology Open Access

ISSN: 2574-187X

Real Cathode and Anode of Internal DC Electric Circuit in FL Lamp

Lyuji Ozawa

Author Details: Lyuji Ozawa, Consultant on Applied Science, 60-2-403, 30 Litung Lu, CVhanpin Qu, Beijing, China 102209, Tel: 86-010 8176 3872; Email: rotsun4@hotmail.com

Received Date: November 26, 2018

Published Date: January 16, 2019

CITATION: Lyuji Ozawa. Real Cathode and Anode of Internal DC Electric Circuit in FL Lamp. Nanomed Nanotechnol 2019, 000eB-001.

Published by



MEDWIN PUBLISHERS

Committed to Create Value for Researchers

Table of Contents

Abstract	1
Introduction	1
Established Fluorescent Lamps in Past for 90 Years	2
Invalidated Technologies of Established HCFL Lamps	3
No Thermoelectron Emission from Heated BaO on W-Filament Coil	
Wrong Assignment of Generation Energy of Lights of HCFL Lamps	
Wave form at Electrodes of HCFL Lamps	
No Poison of Hg Atoms in FL Lamps to Human Body	
New Lighting Mechanisms of FL Lamps	6
Ar Gas Space in Unlighted FL Lamps is Electric Insulator	
Lighting Mechanisms of HCFL Lamps	
Coexistence of Disparities of External AC Driving Circuit and Internal DC Driving Circuit in Lighted FL Lamps	
New Lighting Mechanisms without Heat of Ar Atoms in Front of Electrodes	
Development of Prototype of Coil-EEFL Lamp	18
Conclusions	22
References	23

Abstract

FL lamps are operated with the coexistence of disparate external and internal electric circuits. FL lamps light up with the internal electric circuit, in which cathode and anode are separately, but simultaneously, formed by volume of glow or corona light in Ar gas space at both ends of FL lamps, under the electric field from electrodes of the external electric circuit. The developed coil-EEFL lamps light up under AC and DC external driving circuits. Under the AC driving circuit, only C_{phos} involve in the W_{AC} that is less than one tenth of the W_{AC} of the HCFL lamps. Under the DC driving circuit, $W_{\text{DC}} = 0$. The feature of FL lamps is the superconductive vacuum at above room temperatures, giving rise to astronomical quantum efficiency [$\eta_q = 10^{13}$ visible photons $(\text{m}^3, \text{s})^{-1}$ per one moving electron]. Each FL lamp is operated with 10^{12} electrons per second. Consequently, the coil-EEFL lamps steadily emit the 10^{25} visible photons $(\text{m}^3, \text{s}^{-1})$. The LED lamp has only $\eta_q < 1.0$. All components of the coil-EEFL lamps reserve in the operation, resulting in the life $> 10^6$ hours. The developed coil-EEFL lamps surely contribute to the COP project of UN with the reduction of the electric power $> 30\%$ on the world.

Keywords: Green Energy; FL Lamp; Quantum Efficiency; Power Consumption; Operation Life

Introduction

Human have daytime activity for more than 5 million yeas under the slightly overcasted sky by thin clouds. Naked eyes of human adjust to daytime sceneries that continuously generate 10^{25} visible photons $(\text{m}^2, \text{s})^{-1}$; corresponding to luminance $(300 \text{ cd}, \text{m}^2)$ or illuminance $(300 \text{ lm}, \text{m}^2)$. The human activities extended to nighttime with the illumination of dark. First illumination source was the fire flame by chemical reactions with oxygen in air. The heated temperatures of fire flame are determined by amount of change in entropy. Illumination by fire flame has called as the candescent lamps. The word of the candescence comes from ancient Greek that mean fire flame. The illumination by the candescent lamps is a very low level as compared with the daytime sceneries. After finding of invisible electrons and atoms in materials and in gases, the lighting sources shift to the incandescent lamps that mean no use of fire. If you refers Webster's Dictionary, the incandescent lamps is defined with the W-filament lamp that was the first incandescent lamp on early 1900s. After the W-filament lamp, the FL lamp and LED lamp have developed using gases and solids without fires. If your brain is AI computer, you may assign only W-filament coil as the light source, and you never assign FL lamps and LED lamps as the incandescent lamps. Here we take the original definition of the incandescent lamp, not the Webster's Dictionary. The incandescent lamp is not use the fire flam. FL and LED lamps generate visible lights by moving electrons in gases and solids respectively. Size of electron is $5.6 \times 10^{-15} \text{ m}$, and size of atoms is around 10^{-9} m . They are invisible sizes by the naked eyes. The study on the FL and LED lamps steps in the abstraction shown in Figure 1. The modern sciences have developed with the abstractions by the scientific evidences.

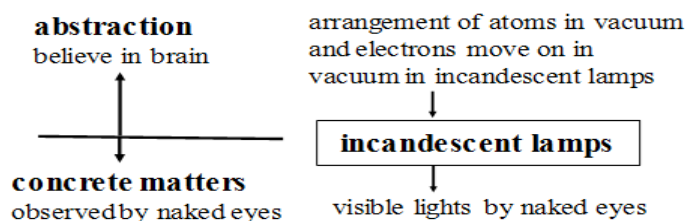

Figure 1: Illustration of abstract and concrete matters on study on incandescent lamps

The lights from the incandescent lamps are generated by the moving electrons in metal, solid and gases. Electron is a quantum. The figure of the merit of the incandescent lamps is given by the quantum efficiency (η_q). The η_q is given by the numbers of the emitted visible photons per one moving electron in the incandescent lamps. The W-filament lamp emits the lights which distribute from the UV lights to the infrared lights. We cannot determine the η_q of W-filament lamp. The LED lamp is made with the solids. The LED lamp generates one visible photon by injection of a pair of electron and hole. The injected electron and hole to LED lamp recombine at the luminescent center. The recombination of the pair of electron and hole generates a photon. The moving electron and hole in sold inevitably lose some amount of the kinetic energy by the electric resistance (R), resulting in the $\eta_q < 1.0$; many case $\eta_q \approx 0.5$ [1]. The commercial hot cathode (HC) FL lamp generate astronomical $\eta_q = 10^{25}$ photons $(\text{m}^3, \text{s})^{-1}$ [1].

According to the COP 21 (Conference of Particles 21), the consumed electric power with the illumination on the world is around 31 % of the totally generated electric power on the world. With this reason, we have attention to the FL lamps as the energy saving light source. The operation of the FL lamps may have a potential to the contribution to the antipollution

on the world. However, the AC driving circuit of established HCFL lamps consumes large amount of the electricity. We have challenged to reduce the electric power consumption of the FL lamps to nearly zero. This report will describe the results of our challenges.

Established Fluorescent Lamps in Past for 90 Years

The studies of the lightened gases in the glass tubes have a long history. First lighting tube is called as the Geissler tube under the high frequencies on 1859. On 1903, John Sealy Townsend had reported the volume of the Ar glow light on the needle electrode. Recently, we have confirmed that the volumes of the glow light on the needle electrodes that respectively have the positive and negative potentials form as the cathode and anode in the inside of the Ar gas space in the vacuum-sealed glass tubes [1]. We assigned the volumes of the glow light in the vacuum-sealed glass tube as the third generation (3G) of the electron sources. However, after the Townsend report for more than 100 years, the scientists of the FL lamps never paid their attention to the 3G volumes as

the cathode and anode in the vacuum-sealed glass tube. The scientists and engineers paid their attention to the Geissler tube.

After 67 years later from the Geissler tube, the hot cathode (HC) FL lamps had invented by R. R. Machelet on 1926 [2] and by F. Meyer on 1928 [3] using the vaporized Hg atoms in the Ar gas space. Then many scientists and engineers paid their attentions to the development of the HCFL lamps by using the W-filament coils with the BaO particles as the cathode and anode. They had believed that the heated BaO particles on the W-filament coils directly emitted the electrons into the Ar gas space, without a confirmation of the formation of the cathode and anode of the BaO particles. They have developed the practical 40W-HCFL lamps in 3.2×10^{-2} m outer diameter (T-10) with 1 m long, as shown in Figure 2. There is a limitation with the outer diameter of the HCFL lamps. If the out diameter of the HCFL lamps is narrower than 2×10^{-2} m (T-7), the light output from the HCFL lamps significantly downs to a low level. As the diameters narrower than 1.0×10^{-2} m, the HCFL lamps did not light up. There is no report why the practical HCFL lamps are produced with the outer diameters wider than 2×10^{-2} m.

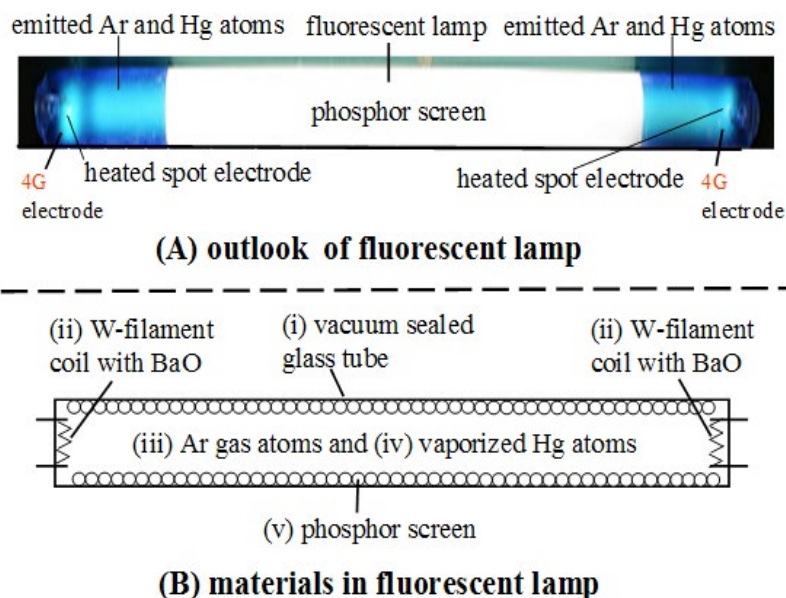

Figure 2: Schematic explanation of HCFL lamp. (A) is outlook of lighted FL lamp and (B) illustrates five components of HCFL lamp.

As shown in Figure 2 (B), the HCFL lamp is assembled with five (5) components. They are (i) vacuum-sealed glass tube, (ii) W-filament coils with BaO particles at the both ends of the vacuum-sealed glass tube, (iii) Ar gas at gas pressure around 930 Pa (= 7 Torr), (iv) vaporized Hg atoms at around 0.1 Pa ($\sim 10^{-3}$ Torr), and (v) phosphor screen on inner wall on the vacuum-sealed glass tube as the conversion from the UV

lights to the visible lights. Then they had studied the details of the lighting mechanisms of the 40W-HCFL lamps with their capabilities. The systematic studies of the HCFL lamps in USA had terminated before 1980 with the reason that no room remains for the further improvement of the qualities of the HCFL lamps.

The published reports before 1980 are summarized in many review articles, Handbooks, books and reports before 1993 [4-15]. If you study on the production technologies of the HCFL lamps in the publications, you surely have a conclusion that the technologies of the HCFL lamps are well optimized as the mature technology. No room left for a further improvement of the HCFL lamp. Then everyone believes that the technologies of the commercial HCFL lamps are the mature technologies. Figure 3 gives a typical result by them. The results in Figure 3 look like the good analyzed results with the sciences. But we find it is the false results. There are many false stories in the established Handbooks and review articles of the HCFL lamps. We must clarify the false results in the study on the HCFL lamps at first.

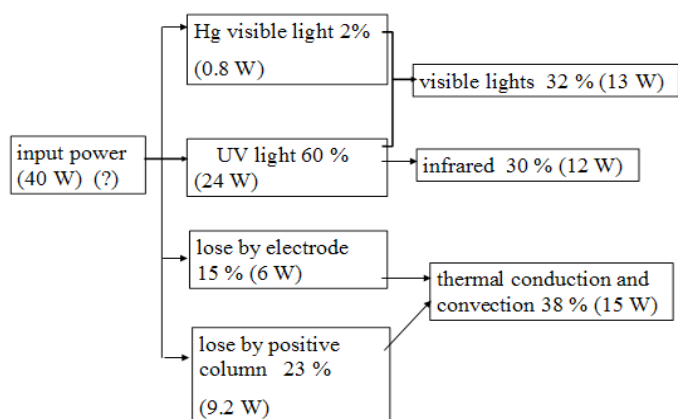

Figure 3: Established energy sharing diagram of 40W-HCFL lamp [5,7].

Invalidated Technologies of Established HCFL Lamps

We have a question about the established technologies of the HCFL lamps. We have found that the basics of the established technologies of the HCFL lamps build up with the erroneous concepts as the science. For instance, (1) the hot cathode (HC) directly emits thermoelectrons into the Ar gas space, and (2) the 40W-HCFL lamp lights up with the input power (40 watt) as shown in Figure 3.

They believe that the heated BaO particles on the W-filament coils directly emit the thermoelectrons into the Ar gas space of the examined HCFL lamp. However, we cannot find the anode that picks up the arrived electrons in their reports. The FL lamp must have the cathode as electron emitter and anode as electron receiver. The FL lamp must light up with the moving electrons from the cathode to anode. They talk about only cathode, but they do not talk

about the anode of the HCFL lamp. We cannot find the anode in the HCFL lamp. With the incomplete electric circuit of the HCFL lamp, they have determined the 40 watt power consumption for the generation of the light from the HCFL lamp. This is the fundamental mistake as the scientific study.

Furthermore, they detect the AC voltage at the electrodes of the W-filament coils. They do not detect the electric current by the electrons. Actually, they detect the voltages at the electrodes of the HCFL lamps. The detected voltage at the electrodes of the HCFL lamp is the induced voltages of the capacitor C_{FL} that is formed in the inside of the Ar gas space of the lighted HCFL lamp [1]. Without the confirmation of the cathode and node of the HCFL lamps and the incorrect determination of the electric power consumption at the W-filament electrodes of the HCFL lamp, they have analyzed the 40W-HCFL lamps as the generation energy of the lights from the HCFL lamp. Recently, we have found that the determined power consumption of the 40 watt at the electrodes of the HCFL lamps is not related with the energy of the generated lights from the HCFL lamp. All confusions come from the thermoelectron emission from the heated BaO particles into the Ar gas space. We have found that the thermoelectron emission from the heated BaO particles in the HCFL lamps is also a false story, without scientific evidence. The thermoelectron emission from the heated BaO particles is the basics of the study on the HCFL lamps. The details of the thermoelectron emission into the Ar gas space are below:

No Thermoelectron Emission from Heated BaO on W-Filament Coil

The commercial FL lamps at present time are called as the hot cathode FL (HCFL) lamps. The meaning of the hot cathode is the thermoelectron emission from the heated BaO particles on the W-filament coils. Figure 4 shows the photopicture of the operated W-filament coils at the both sides of the HCFL lamp under the operation with AC 100V, 50 Hz.

You may see that the BaO particles on the W-filament coils do not uniformly heat up the temperatures in the lighted HCFL lamp. The large areas (more than a half area) of the working W-filament coils do not heat up to the temperatures. After turn-off of the lighted HCFL lamps, we have observed the W-filament coils under the optical microscope higher than 500 times. The heated area is assigned as (a) the bear spots (no BaO particle) at the one ends of the W-filament coil, and (b) the BaO particles at nearby the heated bear spots. From the photopicture shown in Figure 4, one may

allow us to say that the large area of the BaO particles on the W-filament coils of the HCFL lamp do not heat up to the proper temperatures (higher than 800°C) for the thermo electron emission. From the observation of the Figure 4, one may allow us to say that the BaO particles on the W-filament coils in the HCFL lamps never emit the thermoelectrons in the lighted HCFL lamps. With other words, the thermoelectron emission from the heated BaO particles in the lighted HCFL lamps is a false story.

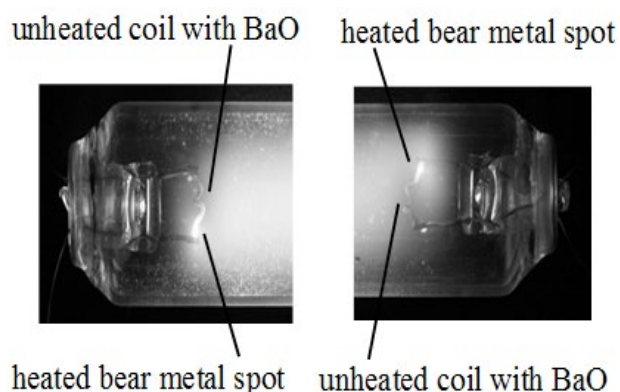

Figure 4: Photopictures of heated BaO particles on W-filament coils at both ends of HCFL lamp.

However, the FL lamps light up with the moving electrons in the Ar gas space in the vacuum-sealed FL lamps. It had stubbornly believed for more than 90 years that the heated BaO particles on and in the W-filament coil emits the thermoelectrons into Ar gas space as the cathode of the HCFL lamps [4-15]. They may assume that the heated BaO particles at other side of the HCFL lamps collects arrived electrons from Ar gas space as the anode of the lighted HCFL lamps. This is a great mistake in the study on the lighting HCFL lamps. The ignorance of the thermoelectron emission from the heated BaO particles generates unbelievable mistake in the study on the lighting mechanisms for last 90 years.

We had the drilled studies on the thermoelectron emission from the heated BaO layers into the vacuum with the development of the cathode-ray tubes (CRT) and vacuum (radio) tubes (VRT). In CRT and VRT, the electrons only move from the cathode to the anode in the vacuum. According to the study on CRT and VRT, there are the restricted conditions for the formation of the cathode and anode by the heated BaO particles. The restricted conditions are (a) the vacuum pressures, and (b) the anode with electric conductive materials. The heated BaO particles steadily emit the thermoelectrons into the vacuum at the pressures less than 10^{-4} Pa ($< 10^{-7}$ Torr). The heated metal cathode of the CRT is covered with the layers of the BaO particles. The metal plate or electric conductive film is used as the anode. With this reason, CRT and VRT are operated with the DC driving

circuit.

There are the large differences between CRT and HCFL lamps. The large differences are (a) the vacuum pressures, (b) the anode and (c) the operation with DC electric circuit. CRTs are operated under the vacuum pressure less than 10^{-4} Pa ($< 10^{-7}$ Torr). The HCFL lamps contain Ar gas pressure at 930 Pa (= 7 Torr) and are operated with the AC driving circuit, without the confirmation of the anode. The operation conditions of the HCFL lamps quite differ from the operation conditions of the CRT and VRT. Thus, the vacuum condition of the heated BaO particles on and in the W-filament coils of the HCFL lamps completely differ from the operation conditions of the CRT. The more details of the studies on the thermoelectrons emission in the CRT are below:

According to the study on CRT, only Ba atoms on the layers of the heated BaO particles emit the thermoelectrons into the vacuum. The BaO particles do not emit the thermoelectrons. The BaO particles are the electric insulators. The heated Ba atoms only exist in the high vacuum. The heated Ba atoms in the low vacuum pressure instantly changes to BaO particles or Ba compounds. The heated BaO particles never emit the thermoelectrons. The metal anode, that has the positive potential against the grand, collects arrived electrons from vacuum. This is the fundamental conditions of the thermoelectron emission from the Ba atoms on the heated BaO particles in CRT and VRT.

By the study on the CRT and VRT, there is a restriction of the vacuum pressures for the thermoelectron emission. So far as the vacuum pressures are lower than 10^{-4} Pa ($< 10^{-7}$ Torr), the vacuum space between floating atoms extends to more than 10 m. Then, the negative electric field from the electrons in the orbital shell of the atoms of the residual gas is a negligible level for the moving of the thermoelectrons. With this reason, the heated Ba atoms at the top layer on BaO particles steadily emit the thermoelectrons to the vacuum at the pressure lower than 10^{-4} Pa ($< 10^{-7}$ Torr). Someone use the getter for the absorption of the residual gases. This is a wrong idea. The activation process of the getters releases a large amount of the gases into the vacuum-sealed CRT. The best way is not use the getters.

Next important item is the amount of the thermoelectrons in CRT. The maximum amount of the emitted thermoelectrons in the CRT devices is around 2×10^{-3} A. The developed CRT and VRT devices are only operated with the DC electric circuit. The heated Ba atoms emit a constant amount of the thermoelectrons per second under the given DC voltage. The amount of the arrived electrons to the anode is controlled by the grid potential in front of the cathode.

As the results of the study on CRT and VRT, there is a

strict limitation for use of the thermoelectrons in the vacuum devices. The strict limitation is the vacuum pressures and the anode as the receiver of the arrived electrons. The heated Ba atoms on the BaO layers are active atoms. The heated Ba atoms react with the residual gas. As the gas pressures higher than 10^{-2} Pa ($> 10^{-5}$ Torr), the heated Ba atoms instantly react with the residual gases. Under the vacuum pressures at 0.1 Pa ($= 10^{-4}$ Torr), the heated Ba atoms on the BaO layers instantly change to the Ba compounds, giving rise to a short operation life of the CRT and VRT. In the vacuum pressures higher than 1 Pa ($> 10^{-2}$ Torr), there is no Ba atoms on the layers of the BaO particles. The developers of the FL lamps ignore the results of the study of the CRT and VRT.

The vacuum pressure of the HCFL lamps is around 930 Pa ($= 7$ Torr) and the vacuum-sealed FL lamps contain the residual gases at around 1 Pa (10^{-2} Torr). If you have studied the BaO in CRT and VRT, you never believe that the HCFL lamps use the thermoelectrons from the heated BaO particles on the W-filament coils in the HCFL lamp. As described above, one may allow us to say that the thermoelectron emission from the heated BaO particles in the lighting HCFL lamps is a false story. We cannot take the thermoelectrons in the study on the FL lamps.

Wrong Assignment of Generation Energy of Lights of HCFL Lamps

Here is another big mistake in Figure 3. The generation energy of the lights from the HCFL lamps is assigned as 40 watt. The 40 watt is calculated with (a) the 4 A of the AC current in the AC driving circuit and (b) the AC 100 V at the electrodes of the HCFL lamp; 40 watt = 4 A \times 100 V. In reality, the amount of the electric current in the inside of the FL lamps is 3×10^{-4} A maximum [1]. The detected voltage at the electrodes of the lighted HCFL lamps is the induced voltage from the capacitor C_{FL} that is formed with the Ar^{1+} in the lighted FL lamps. The determined 40 watt in Figure 3 is not related with the generation energy of the light of the HCFL lamps. Totally, we cannot take the results shown in Figure 3 in the study on the FL lamps.

As the conclusion of the thermoelectron emission, it can say that the concept of the thermoelectron emission of the HCFL lamps is a great illusion in the study on the HCFL lamps for the last 90 years.

Wave form at Electrodes of HCFL Lamps

For a confirmation of the reality of the operation of the HCFL lamps, we have measured the waveforms with an oscilloscope. The HCFL lamp is operated with the AC driving circuit (100 volt, 50 Hz). Figure 5 shows the detected waveforms.

The oscilloscope does not have current sensor. The oscilloscope only detects the change in the voltages between the inserted resistances with the running time at the electrodes. The AC driving circuit of the commercial 40W-HCFL lamp has the ballast (choke coil). We have detected sine wave at any parts, except for the electrodes of the HCFL lamps. We cannot insert the resistance to the electrodes of the HCFL lamp, but we detect the waveform at the electrodes of the HCFL lamp. The W-filament electrodes do not have the sine wave. We have assigned the wave form of the change in voltage at the electrodes of the FL lamp. Then, we have assigned the waveform of the capacitor of the C_{FL} . The capacitance of the C_{FL} is calculated as 86 μF , as shown in Figure 5. However, the developers of the HCFL lamps never consider the capacitor between the electrodes of the HCFL lamp.

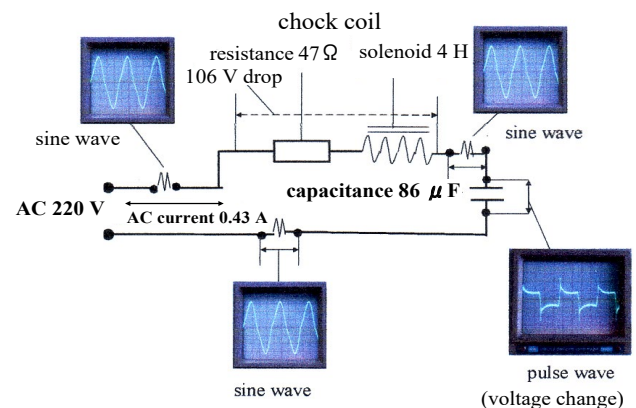

Figure 5: Waveforms on screen of oscilloscope. All components in driving circuit of HCFL lamp have sine wave, except for between W-filament electrodes.

We have had extensively studied on the solid condensers in the past. The waveform detected at the electrodes at the W-filament coil of the HCFL lamp is similar with the typical waveform of a solid capacitor (condenser). The solid capacitor does not allow the flow of the electrons in the inside of the capacitor. The capacitor of the lighted HCFL lamps is also not related with the electron flow in the Ar gas space in the lighted HCFL lamps. Therefore, the determined 40 watt in Figure 3 is the wrong assignment as the science. It is not related with the generation energy of the lights from the HCFL lamps. The detected power consumption at the electrodes of the HCFL lamp is the active power consumption of the capacitor C_{FL} which is only formed in the lighted FL lamp by the ionized Ar atoms (Ar^{1+}). The details of the formation mechanisms of C_{FL} will describe in Chapter 4-2 in this report.

There is another fundamental mistake in Figure 3 that is the consumed power consumption of the HCFL lamp. The

actual AC power consumption, W_{act} , of the AC driving circuit of the 40W-HCFL lamp is 89 watt (= 46 watt + 43 watt) as shown in Figure 6.

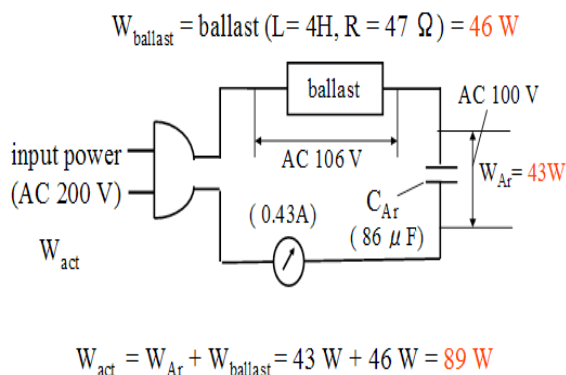

Figure 6: Schematic explanations of AC driving circuit of HCFL lamp and AC power consumptions of W_{act} (= 89 watt) that is composed with W_{Ar} and $W_{ballast}$ and of HCFL lamp

Then, we have many questions about the established technologies of the HCFL lamps. We have carefully studied the HCFL lamps from the fundamentals. We have found many premature technologies in the last 90 years. Then one may allow us to say that the established HCFL lamps are produced with (i) many hypotheses, (ii) misinterpretations of the measured results, (iii) especially the invalid evaluations of the power consumption of the HCFL lamps, and (iv) formation of cathode and anode in Ar gas space in the lighted FL lamps. Then it can say that the established technologies of the HCFL (and CCFL) lamps are the premature technologies that conceal the superiorities of the FL lamps over other incandescent lamps, especially LED lamp.

No Poison of Hg Atoms in FL Lamps to Human Body

Here arises the erroneous action for the study of the FL lamps. The Japanese Government recently prohibits the production of the FL lamps as the poison of Hg atoms to human body, using the Minemata Disease. Then, the Japanese Government has proposed to United Nation for the termination of the usage of the FL lamps on the World as the serious poison of Hg atoms.

The poison of the Hg atoms is a false story to the human body as a science. The Minemata Disease is only caused with the organic Hg compound (CH_3HgX) [16,1]. The Hg atoms never involved in the Minamata Disease [1]. The organic CH_3HgX compound has a small density (density < 1.0 gram), so that the CH_3HgX compound floats in the water. The Hg droplet (density of 13.6 gram) never floats in the water. The heavy Hg droplets in water instantly settle down to the surface

of the sand. The droplets on the surface on the sand instantly penetrate in to the deep layers of the sand. The Minamata Disease is not caused by the Hg droplets. It is caused by the organic CH_3HgX compounds. The existence of the floating CH_3HgX in the contaminated sea water has been detected by the measurements of the absorption spectrum of the Hg atoms. The inspectors should assign as the floating CH_3HgX compound in the contaminated sea water. But the Japanese Government did not take it. The catalytic CH_3HgX compounds have widely used in USA and Europe before the use in Japan. The Japanese imported the technologies from the USA and Europe. There is no report of the disease by the CH_3HgX compounds from USA and Europe. The human societies have a long history (more than 4,000 years) of the use of the Hg droplets and inorganic Hg compounds. There is no report like as the Minemata Disease on the world. The Minamata Disease is caused with the uncontrolled drain water that contains the floating CH_3HgX from a chemical factory to the sea water in Minamata Bay. The Minamata Disease is limited in the very small fishing villages at the Minamata Bay. The Japanese Government does not control the contaminated water with the floating CH_3HgX compounds. The use of the Hg droplets to the FL lamps is absolutely safe for the human health. It has proved with the annual production volume of the HCFL lamps. The multimillions of the HCFL lamps have produced each year for 90 years. There is no report of the Hg diseases. The Japanese Government must officially withdraw their proposal to UN as the poison of Hg atoms in the production of the FL lamps and usage in other products for the contribution to the human society. But the Japanese Governments do not take the withdraw action to UN. It is said again. The Hg droplets are not poison to the human body. The Hg droplets are safety of human body. The Hg droplets are useful material for our daily activity. With this reason, we have studied the details of the FL lamps that have superiority over other incandescent lamps, especially LED lamps that have only $\eta_q < 1.0$. The developed FL lamps, which brilliantly light up with $W_{act} = 0$, will greatly contribute to the reduction of the polluted air on the world.

New Lighting Mechanisms of FL Lamps

As already described in Chapter 2, first lighting tube was reported by Geissler on 1859 under the high frequencies. John Sealy Townsend reported the volume of the glow light on the needle electrodes on 1903. Townsend indicated an important message for us. The needle electrode directly emitted the electrons as the vacuum pressures less than 10^{-3} Pa (= 10^{-5} Torr). But the needle electrode did not emit the electrons in the vacuum at the pressures higher than 10^{-1} Pa (10^{-3} Torr). He did not give us the reason why the needle electrode did not emit the electron in the vacuum higher than 10^{-1} Pa. Then, the needle electrode in the Ar gas was suddenly covered with the glow light under the application

of the 1×10^3 volts. The size of the volume of the glow light did not change with the applied voltages higher than 1×10^3 volts, but the electric current from the volume of the glow light vertically increased at 1 kV with the applied voltages. The commercial HCFL lamps had developed with the concept of the Geissler tube. By the study based on the Geissler tube, they overlooked the vacuum conditions between Ar atoms. The commercial HCFL lamps in outer diameter wider than 2×10^{-2} m (T-6) contain Ar gas pressure at around 930 Pa (7 Torr). For the study on the FL lamps, we take care about the report by Townsend, rather than Geissler tube. For the clarification of the vacuum conditions of the FL lamps, at first, we have studied the vacuum space between Ar atoms in the unlighted FL lamps.

Ar Gas Space in Unlighted FL Lamps is Electric Insulator

The vacuum conditions of the FL lamps quite differ with the unlighted and lighted FL lamps. We will clarify, at first, the vacuum space of the unlighted FL lamps. The Ar atoms float in the vacuum with the Maxwell-Boltzmann distribution. The numbers of Ar atoms in unit volume (m^3) of the vacuum are calculated by the Boyle-Charles Law and Avogadro's number. The vacuum in the HCFL lamp contains 10^{18} Ar atoms per unit volume of 1 m^3 [1]. Average separation distance of the Ar atoms in the FL lamp is 10^{-6} m ($= (10^{18} \text{ m}^3)^{1/3}$), that is more than 10^3 times of the separation distance ($\sim 10^{-9}$ m) of the atoms in solids. Figure 7 schematically illustrates the floating Ar atoms in the vacuum with the average separation distance with 10^{-6} m. The distinguish difference of the FL lamps from the LED lamp is the vacuum condition of the unlighted FL lamps.

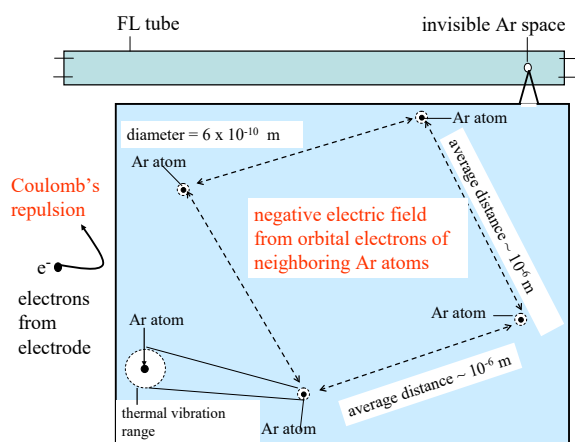

Figure 7: Schematic illustration of vacuum between Ar atoms that fills up negative electric field from electrons in orbital shells in neighboring Ar atoms in Ar gas space in unlighted FL lamp

The vacuum space between Ar atoms fills up with the negative electric field from the electrons in the $3p_6$ orbital shell of Ar atoms, as illustrated in Figure 7. If the metal electrode emits the electron to the Ar gas space, the electron instantly receives the strong Coulomb's repulsion from the vacuum between Ar atoms. The electrons never step in the vacuum between Ar atoms, as illustrated in Figure 7. In the past study, no one considered the vacuum that is filled up with the strong negative electric field in the unlighted FL lamp. The difficulty of the start of the lighting of the FL lamp is caused by the fact that the vacuum between floating Ar atoms fills up with the negative electric field. This is an important subject of the study on lighting mechanisms of FL lamps. For the lighting of FL lamp, how do change the negatively insulating vacuum to a conductive vacuum in the lighted FL lamp. The experimental evidences of the existence of the negative vacuum in the Ar gas space and change to the conductive vacuum had reported by Townsend on 1903. But the scientists never considered the Townsend's comments in the study on the FL lamps.

One may detect the strong negative electric field in the vacuum of unlighted FL lamp by the measurements of the absorption spectrum of the Ar atoms in the unlighted FL lamp. The absorption spectrum consists with the sharp lines, indicating that individual Ar atoms isolate each other's in the Ar gas. The absorption spectrum informs us a further important message. Each absorption line of the excited states splits into many sublevels. The grand level does not split under the electric field. The split absorption lines are caused by the Stark Effect. The Stark Effect shows that Ar atoms are under the electric field. The vacuum space between Ar atoms in the unlighted FL lamps fills up with the strong electric field from the electrons in $3p_6$ orbital shell of Ar atoms, so that the excited levels of Ar atoms split to the plural levels.

Now, we know the vacuum space in unlighted FL lamps fills up with the negative electric field from the orbital electrons in $3p_6$ shell of the Ar atoms. The electrons from the metal cathode never step in the strong negative field in the vacuum of the unlighted FL lamps. For the example, the thermoelectrons from the heated BaO particles on the W-filament coils never step in the vacuum in the Ar gas of the unlighted FL lamp. However, the developers of the HCFL lamps have believed that the thermoelectrons from the heated BaO particles smoothly step in the vacuum of the unlighted HCFL lamps without a proof of it.

In the solid compounds, the negative vacuum field between atoms at around the lattice sites is partially neutralized with the coexistence of the positively ionized atoms at lattice sites. As the consequence, the electrons from the anode on solid compounds step in the vacuum space between atoms in the solids. It should note that the anode

emits the electrons into the solid and the cathode collects the arrived electrons from the solids. If you take the FL lamps like as the solids, you cannot find the lighting mechanisms of the FL lamps. With the FL lamps, the cathode emits the electron in the vacuum and the anode collects arrived electron from the vacuum. The fill-up of the negative field in the vacuum space between Ar atoms is a reality in the study on the FL lamp. For the lighting of the FL lamps, at first, we must find out how neutralize the negative electric field between Ar atoms in the unlighted HFCL lamps.

Lighting Mechanisms of HCFL Lamps

In the reality, the HCFL lamps had developed with the different approach. They had found the brilliantly lighting FL lamp by the application of the W-filament coils with the BaO particles [2,3]. They had believed that the heated BaO particles on the heated W-filament coils at the both sides directly emit the thermoelectrons into the Ar gas space. With this reason, they named the developed FL lamps as the hot cathode FL (HCFL) lamps. In general, the completion

of the electric circuit is made with collection of the moved electrons. With the vacuum devices, the anode collects the arrived electrons. However, we cannot find how collect the arrived electrons in the HCFL lamps. The presence of the anode in the HCFL lamps remains for a future study.

After finding of the brilliantly lighted HCFL lamp, many scientists and engineers involved in the improvement of the HCFL lamps [4-15]. As described in previous Chapter 3, the heated BaO particles in the HCFL lamps never emit thermoelectrons into the vacuum between Ar atoms of the HCFL lamps. Furthermore, the developers of the HCFL lamps never assigned the cathode and anode in their electric circuit of their HCFL lamps. The identification of the cathode and anode of the electric circuit in the lighted FL lamps is an essential requirement for operation of the HCFL lamps. They just studied the optimizations of the lighted HCFL lamps with the try and error approaches. With this reason, it can say that the most fundamental technologies of the established HCFL lamps remain for the future study.

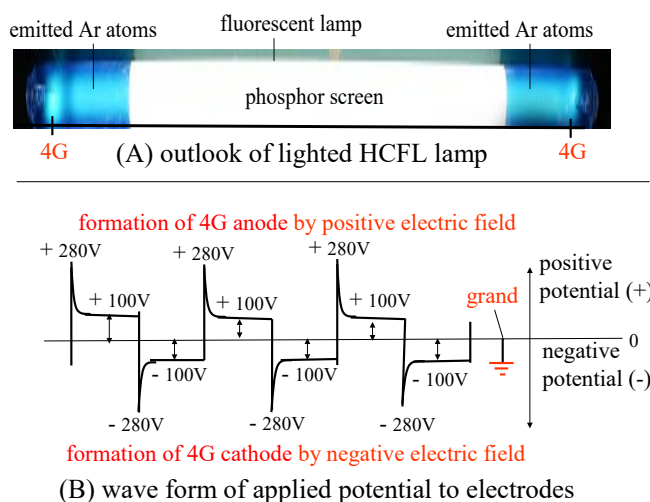

Figure 8: Photopicture of lighted HCFL lamp (A) and waveform of applied AC 100 volt with 50 Hz (B)

The commercial HCFL lamps brilliantly light up with the operation of the AC driving circuit that has the AC 100 volt with 50 (or 60) Hz. Figure 8 (A) shows the photopicture of the lighted HCFL lamp. You may see in Figure 8 (A) and Figure 2 (A), the W-filament coils at the both ends of the HCFL lamp are covered with the 4G volumes. The 4G volumes and shapes differ with the W-filament coils in the same HCFL lamps and with the different HCFL lamps. The different volumes and shapes indicate no quality control of the formation of the 4G volumes on the W-filament coils.

Figure 8 (B) shows the waveform at the electrodes of

the both sides of the lighted HCFL lamp. The positive and negative potential of the wave forms are given by the potential against to the grand (Earth) that has zero potential, as shown in Figure 8 (B). The waveforms are given by the change in the applied voltages to the electrodes at the both ends, as a function of the running time for 20 ms ($= 50^{-1}$ second) for one cycle. The waveforms shown in Figure 8 (B) clearly indicate us that the given W-filament coil electrode of the HCFL lamp at one side only has the positive potential for 10 ms and for the next half cycle, the W-filament electrode at other side has the negative potential for following 10 ms. The HCFL lamps never have the coexistence of the negative potential (cathode)

and positive potential (anode) in the given half cycle (10 ms). This means that the electrodes in the HCFL lamp never form the electric circuit in the operation with each half cycle. The lighted HCFL lamp must have the coexistence of the cathode and anode in each half cycle (10 ms) for the formation of the electric circuit. Then, the electrons move from the cathode to the anode. However, we cannot find the coexistence of the cathode and anode from the waveform shown in Figure 8 (B). However, the HCFL lamps light up with the AC driving circuit. We cannot find the reason of the lighting of the HCFL lamp from the measured waveforms. For the lighting of the HCFL lamps under the AC driving circuit, we must find out a new lighting mechanism of the HCFL lamps. For finding out the lighting mechanism of the HCFL lamp, we have studied with the W-filament coils, without the BaO particles. Unfortunately, we cannot light up the HCFL lamps with the AC driving circuit.

The subject of the lighting mechanisms in the HCFL lamps by the AC driving circuit steps in a most fundamental subject of the lighting mechanisms of the HCFL lamps. The fundamental subject should find the coexistence of the cathode and anode for a half cycle of the AC driving circuit. As already described, the BaO particles on the W-filament coils cannot assign as the cathode and anode of the FL lamps. We must find out the real cathode and anode in the lighted HCFL lamp. The lights of the HCFL lamps are generated with the results of the moving electrons between the cathode and anode. We may find the real lighting mechanisms of the HCFL lamps.

For finding of the lighting mechanisms of the HCFL lamp under the AC driving circuit, we have studied with the W-filament coil without the BaO particles. Then we have the interesting results. As the W-filament coils heat up to the higher than 500°C, the heated W-filament coil at one side has the positive potential (+) against to the grand (zero potential), the heated W-filament coil is covered with the volume of the corona light that is assigned (+ 4G) electron source. The volume of the + 4G electron source on the heated W-filament coil holds the following half cycle, even though the electrode does not have electric potential. With the repetition, the + 4G volume always stay on the W-filament coil of the positive side, as illustrated in Figure 9. We have the same story with the heated W-filament coil at the opposite side of the HCFL lamp that has the negative potential against to the grand. We detect the volume of the corona light (- 4G) on the W-filament coil that has the negative potential for the half cycle. The volume of the - 4G corona light continuously holds for operation time as illustrated in Figure 9. Here is a serious problem that is the operation life of the W-filament coil. It is shorter than 10^2 hours with the continuous heating of the W-filament coils.

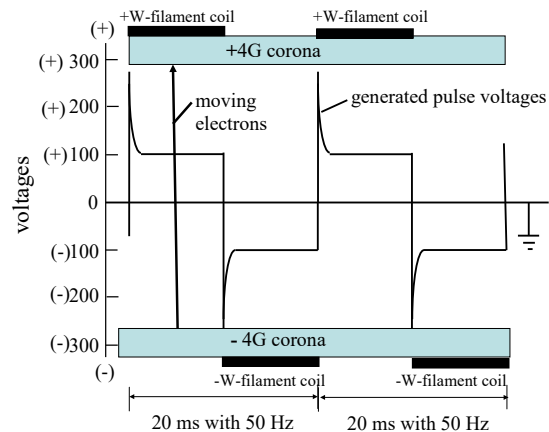

Figure 9: Formed volumes of corona light (4G) on respectively heated W-filament coils at positive potential (+) and negative potential (-) for each half

Then, we have studied the W-filament coils with the BaO particles. We have an ideal condition of the packing of the BaO particles in the W-filament coils. Figure 10 shows the photopicture of the W-filament coil that we have it in our hands. Then, the W-filament coil set in the HCFL lamp without the phosphor screen. In this case, the W-filament coils do not have the heating circuit.

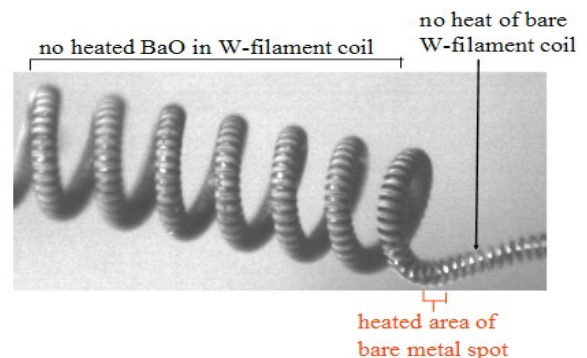

Figure 10: Photopicture of ideal W-filament coil with BaO particles.

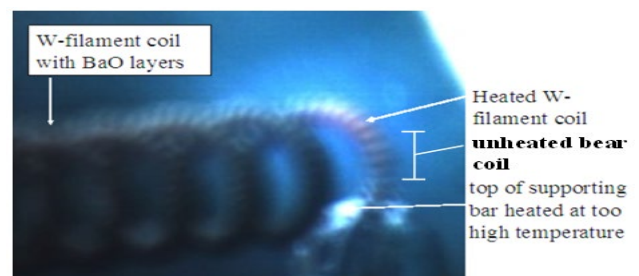

Figure 11: Photopicture (x 50) of working W-filament coil with BaO particles in lighted HCFL lamps operated with 30 kHz

The HCFL lamps, without phosphor screen, are operated with the AC driving circuit with 450V, 30 kHz. Figure 11 shows the photopicture of working W-filament coil with BaO particles in the lighted HCFL lamp. The heated area of the W-filament coil with the BaO particles is limited as a very small bear spot area at one side of the W-filament coil, as shown in Figure 11. The large area of the W-filament coil with the BaO particles does not heat up to the temperature under the eyes observation. You may also see that the large bear coil area, without the BaO particles, is not heat up the temperature in the operation of the HCFL lamp. The heated area in the W-filament coils is limited as a very small area that is the small bear spot area with the BaO particles. Then, we have studied the working W-filament coils in the commercial HCFL lamps that are operated with the AC 100V, 50 Hz, without the phosphor screen.

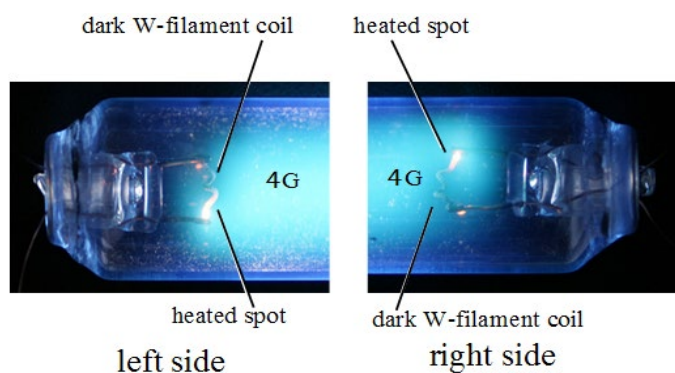

Figure 12: Photopictures of heated spots of working W-filament coils at the both end of HCFL lamp. Ar atoms in heated volume at around heated spots are ionized with electric field from W-filament coils.

Figure 12 shows the photopicture of the working W-filament coils with the BaO particles at the both ends. We have found that the large volume of the Ar gas at around the heated bear spot continuously lights up with the sky-blue lights with the help of the heated BaO particles that have the large heat capacity. The lighted volume and shape are changed with the variation of the bear spots in the W-filament coils with the BaO particles, as shown in Figure 2 (A), Figure 8 (A) and Figure 12. The variations in the sizes and figures of the 4G volumes are caused with the uncontrolled condition of the preparation of the W-filament coils with the BaO particles. However, the variations of the sizes and figures of the 4G volume are not serious troubles for the operation of the FL lamps. However, for the production of the HCFL lamps, it is a better way that the size and shape of the 4G volumes should be under the control for the quality control of the production of the HCFL lamps.

The details of the formation of the 4G volume for one cycle, not the half cycle, at around the W-filament electrodes are

below. The thermal radiation from the heated spot selectively heats up the limited volume of the Ar atoms at around the bear spot of the W-filament coil to a temperature at about 80°C that is determined by the infrared thermometer. With the limited BaO particles at around heated bear spots heat up by the heat conduction from the heated bear spot of the W-filament coil. Since the heated BaO particles have the large heat capacitance, the heated BaO particles may hold the temperature for the unheated half cycle. Therefore, the 4G volume at around the bear spot is continuously heated for one cycle with the help of the heated BaO particles at nearby the heated bear spot of the W-filament coil. The ionization of the Ar atoms in the unheated Ar gas requires the high electric field (F_{filam}) from the W-filament coil for a half cycle. And the 4G volume holds for the following half cycle with the help of the heated BaO particles at the nearby the heated spot. Consequently, the 4G volumes continuously form on the electrodes. In practical HCFL lamps, the 4G volumes always form on the W-filament coils at the both end sides of the HCFL lamps. Thus, the 4G volumes are actual electron sources that are the cathode and anode in the lighted HCFL lamps.

Now we will describe the details of the Ar atoms in the heated 4G volumes on the W-filament coils under the operation with the AC driving circuit with 100V, 50 Hz. The heated volumes contain large amount of Ar^{1+} , free electrons (e^-), and excited Ar atoms (Ar^*). The Ar^{1+} and e^- are the same numbers. The numbers of Ar^* are less than 0.08 of Ar^{1+} [1]. The majorities in the 4G volume are the invisible Ar^{1+} and e^- . Mass of Ar^{1+} is 1.6×10^{-27} kg, and mass of electron is 9.1×10^{-31} kg. The negative electric field in the volume of the corona light is neutralized by the presence of the positive charges of Ar^{1+} . Therefore, the electrons in the 4G volume smoothly move on in the neutralized vacuum in the 4G volume. This means the 4G volume, which is formed on the negative potential of the W-filament coil, may act as the electron source in the Ar gas space. The 4G volume on the positive W-filament coil may act as the anode that correct the electrons from the Ar gas space. Thus, the \pm 4G volumes on the W-filament coils at the both ends may act as the cathode and anode. Here we have found the internal DC electric circuit in front of the W-filament coils, without the electron flow from the W-filament coil to the 4G volumes. However, here is a problem.

As already mentioned, the bear metal spot in the W-filament coils do not heat up for the following the half cycle. The cathode and anode must coexist in each cycle of the external AC driving circuit. Therefore, we must solve the fundamentals of the formation of the internal DC driving circuit in the HCFL lamp, under the external AC driving circuit.

We have found a way that the continuous holding of the 4G volumes on the W-filament coils for one cycle. The heated BaO particles have the high heat capacitance. With the help of the heated BaO particles, we have solved the most difficult subject in the studies of the lighted HCFL lamps. By the help of the heated BaO particles at around the heated bear metal spot in the W-filament coil, the heated bear metal spot holds the temperature of the 4G volume for the following half cycle (1×10^{-2} seconds with 50 Hz). This is a main reason that the W-filament coils use the BaO particles.

Here is another requirement. In the operation of the FL lamps, the bear spot of the W-filament coil that has the positive potential is heated by the stream electron beam from the 4G volume, as illustrated in Figure 13. Following half cycle, the W-filament coil at the other side has the negative potential, so that the bear spot is heated by the Ar^{1+} particles in the 4G volume as illustrated in Figure 14. The BaO particles at the nearby the bear spots are also heated by the heat conductance from the heated bear spots. The 4G volumes on the W-filament coils always exist on the W-filament coils in the lighted HCFL lamp. Thus, the 4G volumes always hold on the W-filament coils. as illustrated in Figure 15. The lights from the HCFL lamps are generated by the moving electrons from the cathode of the 4G volume to the anode of the 4G volume, without the electron flow from the external AC driving circuit.

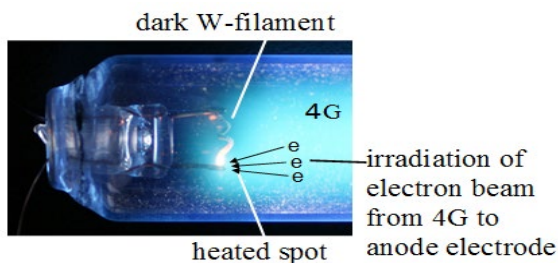

Figure 13: Heat of bear spot of positive W-filament coil for a half cycle by irradiation of electrons from volume of 4G corona light.

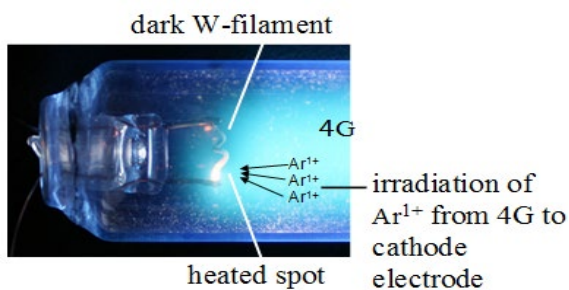

Figure 14: Heat of bear spot of negative W-filament coil for half cycle by irradiation of Ar^{1+} from volume of 4G corona light

Thus, we have theoretically and practically solved the difficulty of the holding of the 4G volumes for one cycle under the operation of the AC driving circuit. Two disparate electric circuits, the external AC driving circuit and the internal DC electric circuit, involve in the operation of the HCFL lamp. The lights from the HCFL lamp are generated with the moving electrons in the internal DC electric circuit formed in the Ar gas space, as illustrated in Figure 15. The electrodes of the external AC driving circuit only help the formation of the internal DC electric circuit by the electric field from the electrodes.

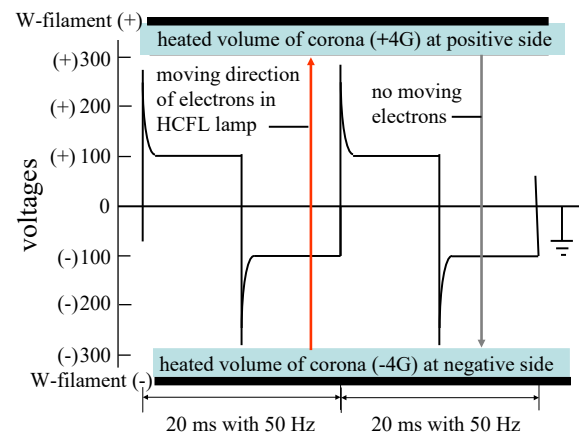

Figure 15: Respective formations of 4G volumes on positive W-filament coil and on negative W-filament coil. Lights are generated by moving electrons in internal DC driving circuit which is formed with $\pm 4G$ volumes in Ar gas space.

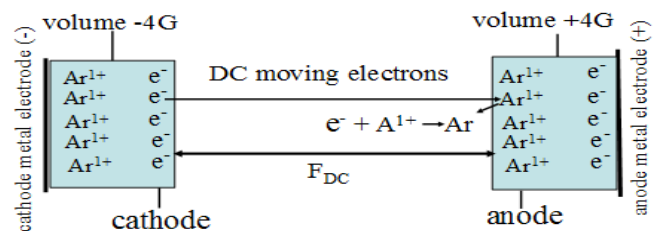

Figure 16: Schematic illustration of distribution of Ar^{1+} and e^- in volumes of corona light (4Gs) and moving direction of electrons between cathode and anode. Arrived electron recombines with Ar^{1+} and returns to Ar atom.

Figure 16 illustrates the details, with the atomic levels, of the internal DC driving circuit. The e^- and Ar^{1+} in the 4G volume are not uniformly distributed in the $\pm 4G$ volumes. Following are the details of the working mechanisms of the 4G electron sources. The electric field from the negative metal electrode (-) attracts the Ar^{1+} , but the negative metal electrode does not take out the Ar^{1+} from the - 4G volume. The attracted Ar^{1+} stays in the surface area of the - 4G volume as illustrated in Figure 16.

The electrons in the -4G volume repulse from the negative metal electrode and the repulsed electrons distribute to far from the metal electrode in the -4G volume. The repulsed electrons in the 4G volume smoothly take out from the -4G volume by the electric field F_{DC} between cathode and anode of the internal DC electric circuit, as illustrated in Figure 16. The taken out electrons neutralize the negative electric field between Ar atoms by the ionization of the Ar atoms. Then, the electrons move to the vacuum in the Ar gas space up to the anode. Arrived electrons to the +4G volume are recombined with the Ar^{1+} . The recombined electron and Ar^{1+} return to Ar atom. There is no consumption of the Ar atoms and electrons in the lighted HCFL lamps, promising the long operation life. The evaporation of the W-atoms from the heated bear spot in the W-filament coil determines the operation life of the HCFL lamps. The operation life of the HCFL lamps is around 500 hours with operation with 50 Hz, and the operation life extends to 10^4 hours by the operation with 30 kHz.

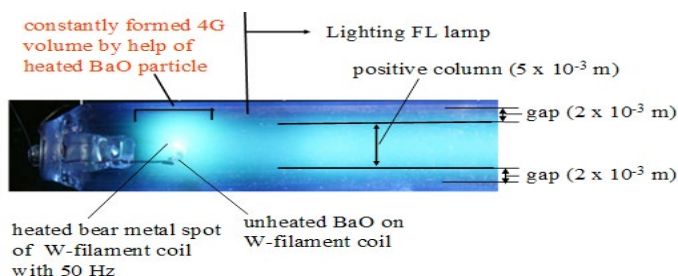

Figure 17: Photopicture of lighted HCFL lamp without phosphor screen

Figure 17 shows photopicture of lighted FL lamp in the out diameter as 1.0×10^{-2} m, without phosphor screen. You may see the extension of the diameter of the 4G volume to the inner diameter, 8×10^{-3} m. There is dark light in front of the 4G volume. The dark light area is caused with the generation of Ar^{1+} and free electrons. The length of the dark area changes with the Ar gas pressures. There is no dark area with the Ar gas pressure at 1×10^5 Pa (~ 100 Torr). The electrons from the 4G cathode only move on in the positive column that forms in the center volume of the FL lamp as shown in Figure 17. There is the gap between the positive column and the inner glass wall. The surface of the inner glass wall has the negative electric charges that generate the negative electric field. The approaching electrons to the charges on the inner glass wall receive the Coulomb's repulsion. The electrons from the cathode only move on in the center volume, i.e., positive column.

So far as the HCFL lamps have the phosphor screens, the phosphor screens also have the large amount of the negative electric charges. Therefore, the ordinal HCFL lamps have the deep gaps between the positive column and inner glass

wall. The optimized HCFL lamps always have the gaps at the around 3×10^{-3} m depth. The depths of the gaps remarkably change with the thickness of the phosphor screens with the same phosphor powder. The depths of the gaps also change with the screening technologies of the same phosphor powders. The subject of the minimization of the gap refers to the references [17-22].

Here arises another limitation of the operation of the HCFL lamps. If the high AC voltages apply to the W-filament coils of the HCFL lamp, the HCFL lamp has the arc discharge as shown in Figure 18. For a long hour operation, the HCFL lamps should be operated with the low AC driving voltage as possible. The optimized AC voltages are determined individually with the given production conditions of the FL lamps.

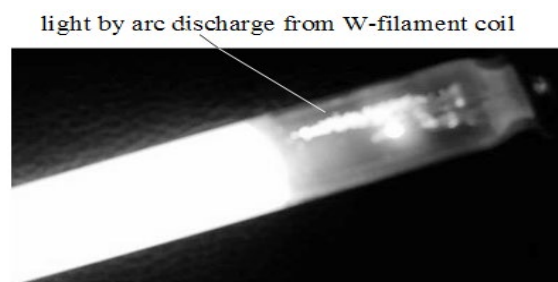

Figure 18: Photograph that has arc discharge from W-filament coil under operation of AC high voltage.

As described above, the commercial HCFL lamps are operated with the moving electrons from the -4G volume as the cathode to the +4G volume as the anode of the internal DC driving circuit. Now it is clear that the electrodes of the W-filament coils never supply the electrons into the vacuum between Ar atoms in the Ar gas. The electrodes of the W-filament coil are activated with the pickup of the induced voltages from the capacitor C_{FL} in the lighted HCFL lamps. Thus, we have found two disparate electric circuits coexist in the operation of the HCFL lamps. Next, we will discuss the details of the coexistence of the disparate DC and AC electric circuits in the lighted HCFL lamps.

Coexistence of Disparities of External AC Driving Circuit and Internal DC Driving Circuit in Lighted FL Lamps

From the experiments shown in Figures 8, 15 & 16, it is clear that the operation mechanisms of the established HCFL lamps for last 90 years are based on the hypotheses. In the past, the moving electrons in the lighted HCFL lamps have the electric resistance, as illustrated in Figure 19 (A). In the reality, two disparate electric circuits, the external AC driving circuit and internal DC driving circuit, coexist in the operation of the HCFL lamps as shown in Figure 19 (B-1) and

(B-2).

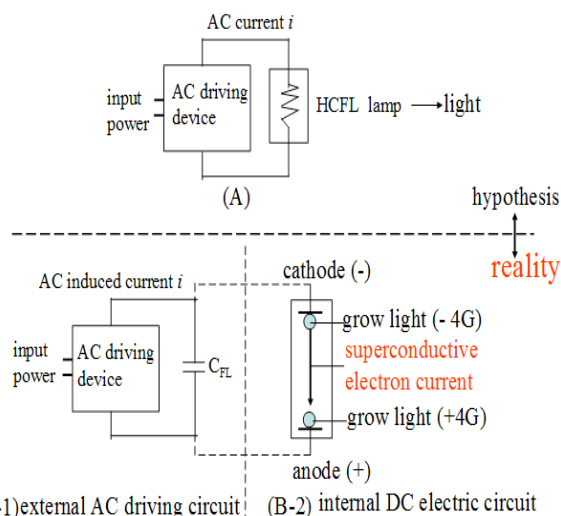

Figure 19: Schematic explanations of traditional electric circuit of HCFL lamp (A) and reality of driving circuits that coexists external AC driving circuit (B-1) and internal DC electric circuit that cathode and anode are respectively formed by 4G volume of corona light on W-filament electrodes in Ar has space (B-2)

The external AC driving circuit is only activated with the induced voltages from the capacitance, C_{FL} , and the AC power consumption of the external AC driving circuit does not relate with the generation energy of the lights of the HCFL lamps. The moving electrons in the internal DC driving circuit only relate with the generation of the lights from the HCFL lamps. The disparities of the external AC driving circuit and internal DC driving circuit always coexist in the operation of the HCFL lamps.

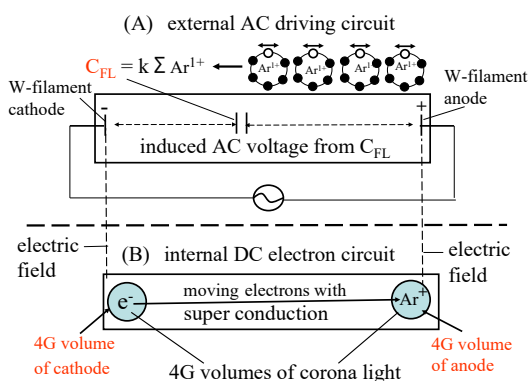

Figure 20: Schematic illustration of coexistence of disparities of external AC driving circuit and internal DC driving circuit in lighted HCFL lamp. Two disparate electric circuits are conjugated with electric field without electron flow

The large difference between them in Figure 19 (B-1) and (B-2) is the electric current in the electric circuits. The W-filament electrodes of the external AC driving circuit only pick up the induced voltages from the capacitor C_{FL} as illustrated in Figure 20 (A). The C_{FL} is formed with the synchronous displacement of the electrons in the upper $3p_6$ electron shell of the Ar^{1+} under the AC driving circuit. The electrodes of the AC driving circuit are only active with the induced voltages from the C_{FL} . However, the detected induced voltage has been called as the induced AC current in the established Handbooks. This is a mistake in the study of the AC driving circuit that contains the C_{FL} . The capacitance of the C_{FL} changes with the numbers of Ar^{1+} atoms in the lighted HCFL lamps: a high capacitance with the high Ar gas pressures. Therefore, the power consumption of the external AC driving circuit does not relate with the generation energy of the lights from the HCFL lamps. We have found the results in Figure 3 as the erroneous results.

The HCFL lamps actually light up with the moving electrons between the cathode of the -4G volume and the anode of the +4G volume. The disadvantage as the lighting source is the operation life less than 500 hours by the cutoff of the heated W-filament coil by the evaporation of the W atoms from the heated bear metal spot. The operation time has extended to around 10^4 hours as the external AC driving circuit is operated with the frequencies higher than 30 kHz.

If we can produce the FL lamp without the heat of the bear metal spot in the W-filament coils, the FL lamps will have a long operation life. Hence, we have found an important and remained subject of the study on the FL lamps. That is the generation of the cathode and anode of the internal DC driving circuit without heat of the bear metal spot of the W-filament coil the FL lamp. We will find a new way that form the cathode and anode in the internal DC driving circuit, without the heat of the volumes of the Ar gases.

New Lighting Mechanisms without Heat of Ar Atoms in Front of Electrodes

The demerit of the HCFL lamps is the operation life shorter than 10^4 hours. The short operation life of the products gives the profit as the business of the HCFL lamps. However, the short operation life of the products generates the air pollution from the operation of the factories of the materials for the FL lamps. From the view point of the antipollution of the air atmosphere on the Earth, the necessary products of our life activity should have a long operation life as possibly. We have found that the FL lamps can be operated with the unheated 3G volumes for the generation of the cathode and anode. By the use of the new 3G volumes, the electric power consumption of the FL lamps significantly reduces to $W_{DC} = 0$. We will describe the details of the formation mechanisms

of the 3G volumes for the lighting FL lamps.

The developed FL lamps have another feature. A significant feature is no loss of the components of the lighting FL lamp, giving rise to the operation life longer than 10^6 hours. The operation life of 10^6 hours corresponds to more than 100 years with the lighting of the FL lamp for 24 hours per day ($= 24 \text{ hrs} \times 365 \text{ days} = 8.8 \times 10^3 \text{ hours per year} \approx 10^4 \text{ hours per year}$). If the FL lamp operates for 10 hours per day, the operation life of the developed FL lamps will be 200 years. Furthermore, the production processes of the developed FL lamps are a very simply as the compared with the production process of the established HCFL lamps so far as the inside of the production facilities hold well maintenance. The long operation life of the FL lamps and the simplified production process of the FL lamps will significantly reduce the air pollution from the production factories at the present level. Thus, the developed FL lamps may reduce the air pollution (more than 30 % of the present level) by (a) the consumed electric power consumption of the lighting FL lamps, (b) elimination of the network of the electricity, and (c) the reduction of the polluted gases from the production factories of the FL lamps on the world. The developed FL lamps may greatly contribute to the green energy project on the world. With those reasons, we will describe the details of the fundamentals of the formation mechanisms of the new FL lamps that are operated with the unheated volumes of the glow light (3G).

Formation of Volumes of 3G Glow Light as Cathode and Anode of FL Lamps

Recently, we have found a breakthrough in the study on the basic mechanisms of the FL lamps. The subject is the formation of the electron sources (i.e., cathode and anode) which are formed in the Ar gas space in the FL lamps. The new cathode and anode of the internal DC driving circuit are formed with the volume of the glow light (3G). The story of the formation of the 3G electron sources backs to 1903. John Sealy Townsend had reported the characteristic properties of the moving electrons from the volume of the Ar glow light on the needle cathode electrode. This is the reason that we have called the volume of the glow light on the needle electrodes as the third generation (3G) electron source. After the Townsend's report for more than 100 years, however, the scientists of the FL lamps never paid their attention to the volume of the glow light as the electron source of the FL lamps. They believed the thermoelectron emission from the heated BaO to the Ar gas space in the HCFL lamps. Furthermore, they believed the amount of the moving electrons in the Ar gas space in the HCFL lamps is around 4A as shown in Figure 3. By the Townsend's report, the maximum DC electron current in the Ar gas space is $1 \times 10^{-3} \text{ A}$. We have found the maximum moving electrons in the Ar gas space of the FL lamps are around $3 \times 10^{-4} \text{ A}$ from the cathode that is close

enough with the Townsend's report. With this reason, we take the Townsend's results as the electron source of the FL lamps. Townsend did not clarify the direction of the moving electrons in the Ar gas space. As described with the analysis of the HCFL lamps, the moving direction of the electrons in the FL lamps is from cathode to anode. In the solids and metals, the electrons move from node to cathode. It is said again that the moving direction of the electrons in the Ar gas space in FL lamp is from cathode to anode.

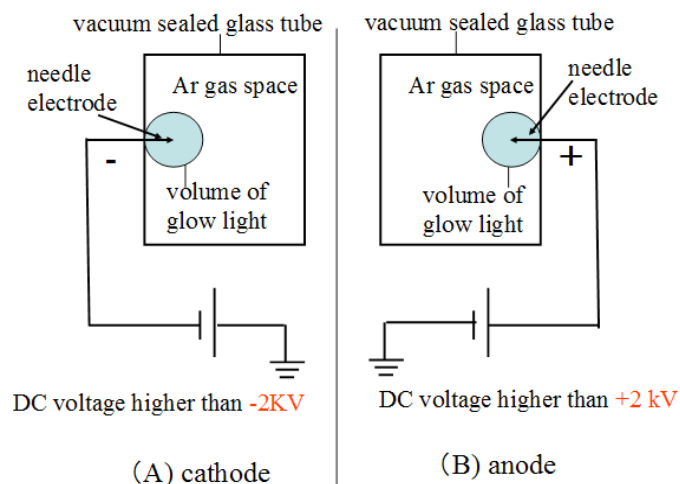

Figure 21: Schematic configurations of volumes of 3G glow light on needle cathode (A) and needle anode (B). Ar gas pressure is 930 Pa (= 7 Torr) [1]

We have studied from the basics of the volume of the glow lights on the needle electrodes in the Ar gas space in the vacuum sealed glass tubes. Figure 21 shows the experimental configurations. We have separately examined the formation of the glow light at the cathode and anode electrodes. We have found that the glow light never forms on the needle electrode with zero potential that is grand (Earth). For the generation of the volume of the corona lights, each electrode respectively has ($> -1.0 \text{ kV}$) as the cathode (A) and ($> +1.0 \text{ kV}$) as the anode as shown in Figure 8. The DC voltages are given by the voltages against the grand (Earth). The threshold voltage changes with the rounded and contaminated needle electrodes. As already shown in Figure 8, the W-filament coils in the HCFL lamps are operated with the AC driving circuit that has the positive and negative potentials against to the zero grand potential (Earth). We have studied the volume of the glow lights on the needle electrodes at $\pm 2 \text{ kV}$, respectively. This is an important care for the study on the volume of the glow light. It is said again that the needle electrode at the $V = 0$ never forms the 3G volume.

Then, we have experiments with the vacuum conditions for the needle electrodes. As the vacuum pressure of the

glass tube is a lower than 10^{-4} Pa (lower than 10^{-6} Torr), the needle electrodes do not have the glow light. The needle cathode electrode directly emits the electrons to the vacuum, and the needle anode electrode never emits the electrons. The emitted electrons have called as the field emission. As the vacuum sealed glass tubes contain the Ar gas at the pressures above 1 Pa ($\sim 7 \times 10^{-3}$ Torr), the needle cathode electrode does not emit the electron under the application of the 0.95 kV. This is because the vacuum space between Ar atoms fills up with the negative electric field from the $3p_6$ orbital electrons of the Ar atoms, as shown in Figure 7.

As illustrated in Figure 21 (A), the needle electrode has the negative potentials above -1.0 kV, the needle electrode is covered with the volume of the glow light of the Ar atoms. The negative potential to the needle electrode is given by the grand (Earth). The generation of the glow light requires the sharpness of the needle electrode. The top of the needle electrodes must have the narrower than 1×10^{-6} m. The electric field of the sharp point of the needle electrode ionizes the Ar atom at around top of the needle electrode. Then, the ionized Ar atom (Ar^{1+}) neutralizes the negative field at around the needle electrode. Then the free electron in the volume of 3G is accelerated by the electric field from the needle electrodes. The accelerated electron ionizes nearby the Ar atoms. Consequently, the needle electrode is covered with the volume of the glow light in the Ar gas space with the thickness at around 3×10^{-3} m. The volume of the glow light does not change with (a) Ar gas pressures and (b) applied voltages to the needle electrodes. The ionization of each Ar atoms generates the Ar^{1+} , free electrons (e), and excited Ar atoms (Ar^*). Ar^{1+} and free electrons are invisible by the naked eyes. Only Ar^* emits the sky-blue lights that are the visible by the naked eyes. We can use the sky-blue light as the monitor of the formation of the 3G volume of the glow lights. The light intensities of the sky-blue light in the 3G volume are changed with the Ar gas pressures; the high light intensities with the high Ar gas pressures. It should note again that the volume of the glow light never appears on the needle electrode that has the grand (Earth).

The similar results are also obtained with the needle anode, as shown in Figure 21 (B). The positive potential to the needle electrode must be given by the grand, as shown in Figure 21. We have confirmed that the 3G volumes of the glow lights respectively form on the needle electrodes. The 3G volumes will work as the cathode and anode of the internal DC electric circuit in the FL lamps. Followings are the practical experiments for the formation of the cathode and anode of the DC electric circuits.

Study on DC Electric Circuit using 3G Cathode and Plat Anode

The first experiments are made with the combination of

the needle cathode electrode and metal plate electrode that is the similar with the experiment by Townsend. If you use the combination of the needle anode and metal plate cathode electrode, you never have the electric current between them, because the anode never emits the electron in to the vacuum device. For the study of the electric current from the 3G electron source, the cathode is made with the 3G volume of the glow light and the anode can be made with the metal plate that has the grand potential ($V=0$). The anode plate electrode never has the 3G volume, but the metal electrode can pick up the arrived electrons.

Figure 22 illustrates the configuration of the experiments for the determination of the moving electron current between electrodes by the use of the DC current meters. We have detected the same amount of the DC electric currents with the both DC current meters. Both electrodes respectively have the DC current meters of 3.0 mA maximum. In the operation of the device, the needle cathode electrode is active as the needle electrode is covered with the 3G volume of the glow light. In the inside of the 3G volume, the negative electric field between Ar atoms, as shown in Figure 7, is neutralized by the presence of Ar^{1+} . Therefore, the electrons in the 3G volume are selectively accelerated under F_{DC} that is formed between 3G volumes of the cathode and the anode. The accelerated electrons step out from the 3G volume to nearby Ar gas space. The stepped out electrons from the 3G volume neutralizes the negative electric field in the nearby Ar gas space. The negative field in the vacuum space between Ar atoms in the FL lamps instantly neutralizes with the moving speed of the electrons ($\sim 10^8$ m per second) from the volume of the 3G glow light under the F_{DC} . The plate anode electrode directly collects arrived electrons. Thus, the electric circuit is closed by the moving electrons from the 3G volume to the plate anode. We may confirm the electric current by the DC current meters at the both sides. The current meters show same amount of the electric currents.

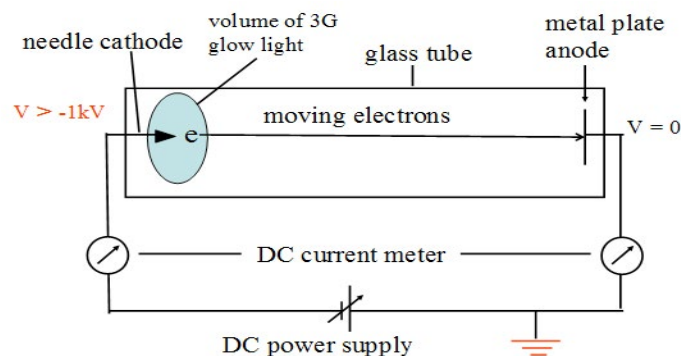

Figure 22: Experimental configuration of flow of electrons between glow light (3G) on needle electrode that has negative potential and plate metal anode electrode that has grand potential.

Then, we have made the confirmation of the Townsend results. So far as the glass tube has the vacuum pressure less than 10^{-5} Pa ($< 10^{-7}$ Torr), the sharp needle electrode does not have the 3G volume. The needle electrode directly emits the electrons into the vacuum as the DC voltage above 12 V. The story changes as the glass tube has the Ar gas pressures higher than 0.1 Pa ($\approx 10^{-3}$ Torr). The needle cathode does not emit the electron with the potentials below 0.95 kV. As the DC voltage of the needle electrode gradually increases, the needle electrode at 1.0 kV suddenly cover up with the volume of the sky-blue light, indicating the formation of the 3G volume. The Ar gases between the needle cathode and plate metal electrode in the test glass tube instantly emits the sky-blue light. Then we have the increase of the applied DC voltages to the cathode above - 2.0 kV. The DC currents between the 3G volume and plate metal anode electrode vertically increases with the constant voltage at 1.0 kV as shown in Figure 23. The results are the same with the reported by Townsend. In that time, Townsend did not know the importance of the vertical increase of the electric current. We know the very important message for the study of the moving electrons in the Ar gas space of the FL lamps.

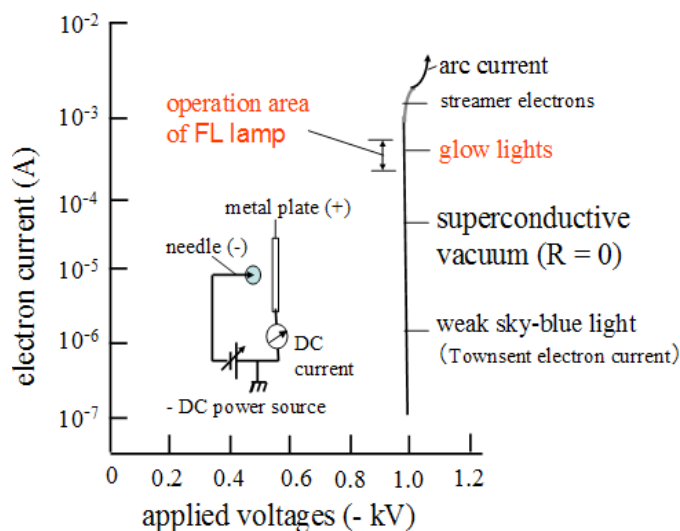

Figure 23: Experimental curve of DC current between needle electrode and plat anode in vacuum at 10^2 Pa.

The constant voltage between the electrodes with the different electron currents indicates that the moving electrons in the vacuum of the glass tube do not have electric resistance (R). Thus we have found that the moving electrons in the vacuum between Ar atoms do not loss the energy by IR ($= V$) with $R = 0$. The electrons in the vacuum in the lighted FL lamps move on in the "superconductive vacuum" at above room temperatures. The superconductive vacuum of the FL lamps is a great advantage over other incandescent lamps. All solid devices have the R , so that the moving electrons in the solids never have the superconductivity at room

temperature. The solid lamps may have the superconductivity at the temperature below -200°C . The results with the Ar gas space give us the significant advantage of the FL lamps. The FL lamps may light up with the superconductive electrons at above the room temperature, possibly at near 100°C . Thus, the FL lamps have the great advantage over the solid incandescent lamps. The maximum electron currents of the practical FL lamps are around 3×10^{-4} A, as shown in Figure 23. Above 4×10^{-4} A, the moving electrons change to the arc current via streamer electron beam.

If you use the combination of the 3G volume and plate electrode in the FL lamps, the properties of the FL lamps change with the surface condition of the plate electrode. It is a better way to make the cathode and anode with the 3G volumes. Figure 24 illustrates the lighted glass tube that has the needle electrodes at the both sides. The DC current meters indicate the same current at the needle electrodes. The results indicated that the 3G volumes at the both sides work as the cathode and anode of the internal DC driving circuit. In this case, the 3G volume on the needle cathode supplies the electrons to the Ar gas space and the 3G volume on the needle anode collects the electrons from the Ar gas space. Thus, the external DC driving circuit is activated with the needle electrodes with the power consumption of 1.2 watt ($= 4 \times 10^3$ V $\times 3 \times 10^{-4}$ A) for the operation of the FL lamps.

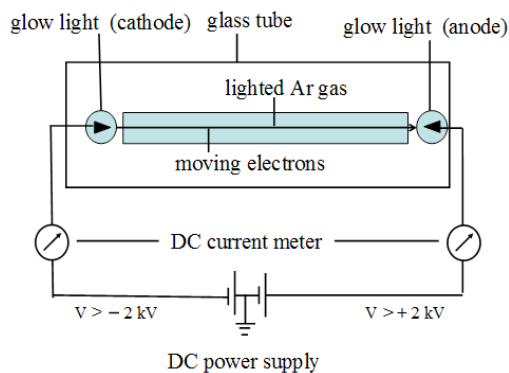

Figure 24: Schematic illustration of lighted column of Ar atoms between volumes of the glow light on needle cathode electrode and needle anode electrode

We have obtsine more information from the experiments as shown in Figure 24. As the needle anode electrode in the FL lamps is covered with the volume of the glow right at the voltage above $+1.0$ kV, the volume of the grow light on the needle anode electrode acts as the collection of the arrived electrons. Then, the 3G anode transfers the received electrons to the needle metal anode in the FL lamp. The sharp point of the needle electrodes never rounded by the Joule Heat in the needle metal electrode. This is because the -3G volume supplies the electrons and the +3G volume receives the

arrived electrons. And then the received electrons transfer to anywhere of the needle anode electrode. The sharpness of the needle electrodes safely works in the lighting FL lamps with the high electron current. The external DC driving circuit has the $W_{DC} = 1.2$ watt. With a curiosity, we have tried the complete removal of the electric power consumption of the external DC driving circuit of the lighted glass tube.

Cut-Off Electron Flow between Needle Electrode and $\pm 3G$ Volume

The 3G volume contains the Ar^{1+} and free electrons. As already shown in Figure 16, the needle metal cathode attract the Ar^{1+} and repulse the electrons in the 3G volume. The distributed electrons (Σe) from the needle cathode may work as the cathode in the FL lamp. The distributed Ar^{1+} from the needle anode may work as the anode (ΣAr^{1+}). If the surface of the needle electrode is covered with the thin electric insulator, like as the frit glass layer, the internal DC driving circuit in the FL lamps may completely isolate from the external DC driving circuit. For the confirmation of this idea, we have made the following experiments.

The surfaces of the both needle cathode and anode are respectively covered with the thin layer ($< 1 \times 10^{-6}$ m thickness) of the frit glass that is the electric insulator. Then the each electrode separately mounts in the Ar gas space at 980 Pa (7 Torr) in the vacuum sealed glass tube, as shown in Figure 25. The 3G volume of the glow light certainly forms on the frit glass layer on the needle electrodes. The threshold voltage for the formation of the 3G volume on the frit glass is the same with that of the bare needle electrodes. Thus, we have confirmed the formation of the $\pm 3G$ volumes are formed on the frit glass layer coving the needle electrodes. The results show us that the 3G volumes of the cathode and anode in the Ar gas are formed without electron flow between needle electrode and the 3G volumes. The 3G volumes as the cathode and anode are respectively formed with the electric field from the electrodes of the external DC driving circuit. The results lead us to the followings experiments.

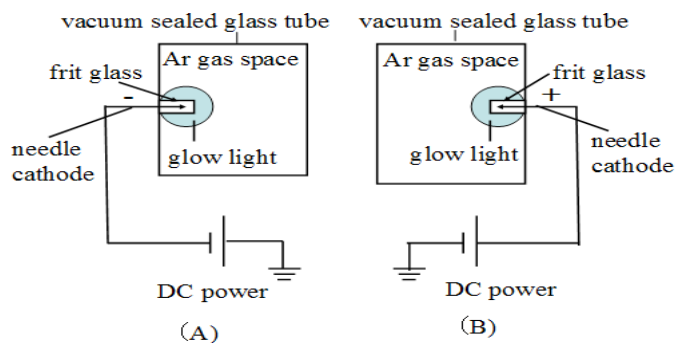

Figure 25: Schematic configurations of volumes of glow light on thin frit glass layer on needle metal cathode (A) and needle metal anode (B). Ar gas pressure is 930 Pa (= 7 Torr)

Then we set in the needle electrodes that are covered with the thin frit glass layer to the both ends of the vacuum sealed glass tube that contains the Ar gas at the pressure at 930 Pa (7 Torr). Figure 26 illustrates the assembled device. The testing glass tubes lights up under DC external electric circuits. The electrodes of the external DC electric circuit do not have the DC electric current that is zero. By the application of DC ± 2 kV each needle electrode at the both sides, the glass tube brilliantly light up with the sky-blue light, nevertheless the DC current meters at the needle electrodes at the both sides show no electric current. The 3G volumes are surely formed without the electron flow from the needle cathodes. We have found a new lighting way of the FL lamps with $W_{DC} = 0$. The cathode and anode of the internal DC driving circuit are formed with the electric fields from the needle metal electrodes that are similar way as illustrated in Figure 16.

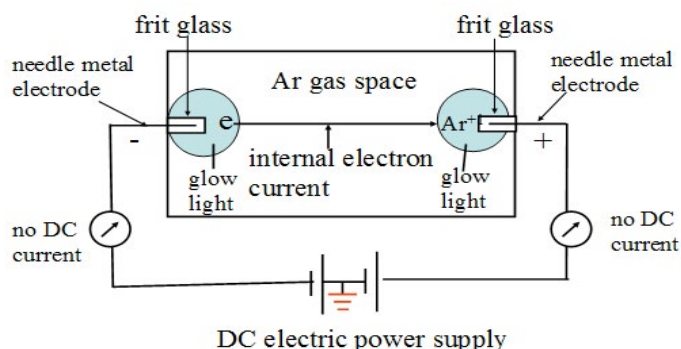

Figure 26: Explanation of moving electrons between volumes of 3G (glow light) as cathode and anode of internal DC electric circuit formed in Ar gas space

The experimental results show us an important information that the FL lamps can be operated without the supply of the electrons from the electrodes of the external DC driving circuit of the FL lamp. This is against the general concept of the electric circuit that has studied in the schools. We have experimentally found that the internal DC electric circuit forms in the Ar gas space in the glass tube by the electric fields from the needle electrodes, without the electric power consumption of the external driving circuit. The discovery actually will contribute to the saving of the operation energy of the FL lamps.

As illustrated in Figure 16, the electrons from the Σe in the 3G volume move on in the vacuum space between Ar atoms toward to the ΣAr^{1+} (3G anode). Arrived electrons to the 3G anode recombine with Ar^{1+} , and Ar^{1+} returns to Ar atoms. Thus, the operation of the FL lamps never consumes the Ar atoms and electrons in the operation of the FL lamps, promising a long operation life.

Development of Prototype of Coil-EEFL Lamp

The results in Figures 26 provide us an idea that is the development of an advanced FL lamp. We may operate the FL lamps with a very simple way, rather than use of the frit glass on the needle electrodes. We have deeply studied the properties of the phosphor particles in the sizes at around 5×10^{-6} m [17]. The practical phosphor particles are the piezoelectric particles that largely deform the crystal structure under the electric field. The deformed phosphor particles have many sharp edge lines and points. The many sharp edge lines and points of the deformed particles may supply the electric field to the Ar gas. The 3G volumes in the Ar gas may form by the electric field from sharp edge lines and points of the deformed phosphor particles in the phosphor screen. If it is so, the FL lamp may light up with the electrodes on outer glass wall of the FL lamps.

Figure 27 shows the photograph of the phosphor particles under the scanning electron microscope (2×10^3 times). The phosphor particles are produced under the special conditions [17]. The average size of the phosphor particles is around 5×10^{-6} m ($5 \mu\text{m}$). The practical phosphor particles are the polycrystalline particles, not the single crystal. The polycrystalline particles have the plural growing axes, generating the many sharp edge lines and points in the sizes smaller than 10^{-7} m, as shown in photograph in Figure 27. The surfaces of the phosphor particles in Figure 27 are contaminated with the very small amount of the residuals. However, it is acceptable for the preliminary experiments of the FL lamps. For the production of the coil-EEFL lamps, you take the clean surface of the phosphor particles as possible.

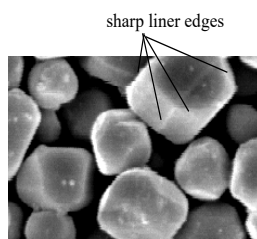

Figure 27: Photograph of scanning electron microscope (x 2000) of produced phosphor particles under control of growth of particles with specified conditions.

If you use the commercial phosphor powders on the market, the surfaces of the phosphor particles are deliberately contaminated with the very small particles of (a) the electric insulator that is the surface treatments and (b) residual particles and thin layers as the residuals from the phosphor production. Figure 28 shows, as an example, the photograph of the scanning electron microscope (x 2,000)

of the commercial phosphor particles. Furthermore, the commercial phosphor particles are the round shapes which have the sharpless edge lines and points. We cannot use the many commercial phosphor powders in the experiments and the production of the coil-EEFL lamps. We like to make the recommendation that you make the test of the phosphor particles under the electron microscope before use it.

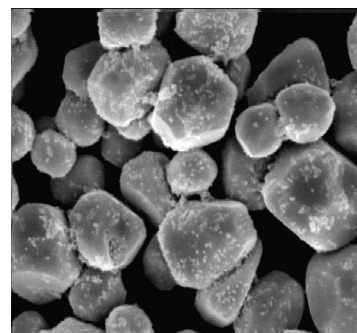

Figure 28: Photograph of scanning electron microscope (x 2000) of unacceptable phosphor particles on market

The next requirements for the study on the advanced FL lamps are the thickness of the phosphor screens on the inner wall of the FL glass tubes. The phosphor screens of many commercial HCFL lamps are produced with the average layers higher than 7 particles. The electric field from the external electrodes (EE) on the outer glass wall significantly reduces with the numbers of the layers of the phosphor particles. The adequate numbers of the layers of the phosphor particles is around 3 to 4 layers. The uniformity of the numbers of the phosphor particles in the screen is an important consideration. Many commercial HCFL lamps have the different numbers of the phosphor particles at the both ends. You may determine the numbers of the layers of the phosphor particles under the scanning electron microscope higher than 1,000 times.

The EEFL lamps have the metal electrodes on the outer glass tube of the FL lamps. We can use either one of (a) the cylinder electrodes or (b) the coil electrodes that are on the outer glass wall. The cylinder electrodes may have a trouble in the operation with the breakout of the vacuum of the cylinder FL lamp. The vacuum break is caused by the arc discharge of the trapped air babbles between glass wall and inside of the metal cylinder. The arc discharge in the cylinder electrodes generates a high temperature to the softening of the FL glass tube. A point of the softened glass makes the pine hole for the vacuum break of the cylinder FL lamp. For the avoidance of the generation of the vacuum break, we recommend the use of the lead wires on the outer glass wall that is the coil-EEFL lamp. The lead wire should be covered with the plastic layer in thickness less than 1×10^{-3} m (= 1 mm). The numbers of the lead wire on the outer glass wall

may have 3 to 5 turns. Then the lead-coil wires strongly push down on the glass wall by the application of the thermally shrinking plastic tube. The shape of the phosphor particles on the inner glass wall are deformed under the electric field from the coiled external electrode (EE) on the outer glass wall of the FL lamps.

Figure 29 illustrates the formation mechanisms of the 3G volume of the glow light on the polarized phosphor particles on the inner glass wall, which are under the electric field (F_{EF}) of the EE on the outer glass wall of the FL lamp. So far as the EE has the negative potential higher than -1.5 kV against the grand, the formed 3G volume works as the cathode of the internal DC electric circuit. As the EE at other side of the FL lamp has the positive potential higher than $+1.5$ kV against the grand, the formed 3G volume on the phosphor particles works as the anode of the internal DC electric circuit. The developed coil-EEFL lamps are operated with the moving electrons from the cathode to the anode under the electric field of F_{FL} .

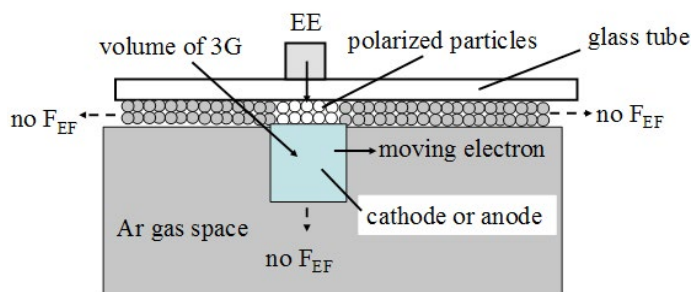

Figure 29: Schematic explanations of formation mechanisms of volume of glow light (3G) by electric field F_{EF} from polarized phosphor particles on inner glass wall. Phosphor particles are polarized under electric field of external electrode (EE) on outer glass wall.

Figure 30 shows the required operation condition of the coil-EEFL lamps. If the electrode at one side of the coil-EEFL lamp connects to the grand potential ($V = 0$) and the electrode at other side of the coil-EEFL lamp connect to the positive potential ($+2$ kV), the coil-EEFL lamp never lights up under the DC driving circuit. This is because the anode of the 3G volume never emits the electrons and the electrode at $V = 0$ never form the 3G volume, as illustrated in Figure 30(A). The coil-EEFL lamp only light up with the simultaneous application of the negative 2 kV to one side electrode and positive 2 kV to other side electrode as shown in Figure 30(B). This is the same condition of the HCFL lamps as shown in Figures 15 and 16. The formation of the 3G cathode and anode at the same time is the necessary condition for the lighting of the coil-EEFL lamps.

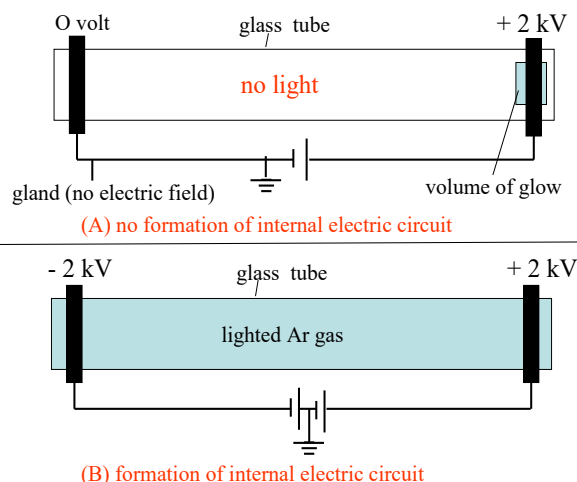

Figure 30: Explanation of formation of lighted coil-EEFL lamp. If cathode electrode has zero potential against grand, FL lamp never lights up because of no electric field from the EE (A). Cathode should have higher than $(-1.5$ kV) and anode should have higher than $(+1.5$ kV) for formation of internal DC circuit inside of FL lamp

Here arises a next requirement for the production of the coil-EEFL lamps. The commercial FL lamps always have the deep gap between positive column and phosphor screen as shown in Figure 17. The depths of the gap of the commercial HCFL lamp are usually 3 to 4 ($\times 10^{-3}$) m. We may calculate the inner volume (V_{tube}) of the FL lamp in the 3.2×10^{-2} m outer diameter (T-10) and 1.0 m length. The inner volume V_{tube} of the FL lamp is 7.0×10^{-4} m³ ($= \pi r^2 \times 1$ m). If the depth of the gap between the positive column and phosphor screen is 3×10^{-3} m, the volume of the positive column (V_{posi}) is calculated as 4.5×10^{-4} m³. The volume of the gap (V_{gap}) is calculated as 2.5×10^{-4} m³ ($= V_{tube} - V_{posi}$). The ratio of (V_{posi}/V_{tube}) is 0.64 and ratio of (V_{gap}/V_{tube}) is 0.36. In this case, about a half of the generated UV lights in the positive column are optically absorbed by the unexcited Hg atoms in the gap before reaching to the phosphor particles. We may calculate the V_{tube} , V_{posi} , and V_{gap} of the outer diameter of 1.3×10^{-2} m (T-5) of the FL lamp. They are respectively $V_{tube} = 7.8 \times 10^{-5}$ m³, $V_{posi} = 0.4 \times 10^{-5}$ m³, and $V_{gap} = 7.4 \times 10^{-5}$ m³. The ratios of (V_{posi}/V_{tube}) = 0.05 and (V_{gap}/V_{tube}) = 0.95. The calculations indicate that the FL lamp of the outer diameter of 1.3×10^{-2} m has negligible volume V_{posi} in the FL lamp. The FL lamps in the narrow diameters require the large reduction of the depth of the gap less than 1×10^{-4} m. The depth of the gap can be controlled by the special arrangement of the phosphor particles in the screen [20,21].

If you reduce the depth of the gap to less than 5×10^{-4} m with the ideal screening technology of the phosphor slurry, the inner diameter of the coil-EEFL lamps is given by the double size of the depth of 3G volumes. The depth of the 3G

volume is $3 \times 10^{-3} \text{ m}$ that does not change with the Ar gas pressures. The best inner diameter of the coil-EEFL lamp is given by $6 \times 10^{-3} \text{ m}$ ($= 2 \times 3 \times 10^{-3} \text{ m}$). The best inner diameter of the coil-EEFL lamp is equal with the diameter of the positive column. As the thickness of the glass wall is around $1 \times 10^{-3} \text{ m}$, the out glass diameter of the coil-EEFL lamp will be $8 \times 10^{-3} \text{ m}$. You may produce the coil-EEFL lamps with the glass tube wider than $9.5 \times 10^{-3} \text{ m}$ (T-3). If your coil-EEFL lamps are converted from the commercial HCFL or CCFL lamps in the outer diameters less than $8 \times 10^{-3} \text{ m}$, you will have a great difficulty with the converted coil-EEFL lamps because the HCFL and CCFL lamps are produced with the production facilities and operation conditions. You also face a difficulty with the DC driving circuits. You must confirm the connection of the DC driving circuit as shown in Figure 30.

The light of the FL lamps is originated by the excitation of the Hg atoms. The Hg atoms in unlighted FL lamps are the small droplets on the phosphor screen on inner FL lamps. Hg droplets on the phosphor screen heat up from the heat radiation from the positive column. Here arises another trouble with FL lamps. The outer glass wall of the FL lamps is cooled with the air convection in the rooms to the room temperature. The gap between the positive column and phosphor screen is the good thermal insulator. Therefore, the phosphor temperature holds at the room temperature. The evaporated Hg atoms from the Hg droplets on the phosphor screen to the positive column are determined the temperature of the outer glass wall that is cooled by the air convection. If you put your coil-EEFL lamps in a vacuum-sealed sheath tube, you have the brilliantly lighted coil-EEFL lamps [22,1]. Then you may face another trouble.

The excited Hg atoms emit the UV lights at mainly 254 nm. The gap also contains the unexcited Hg atoms that optically absorb the 254 nm UV light from the positive column before the reach to the phosphor screen on the inner wall of the FL lamp. The large ($V_{\text{gap}}/V_{\text{tube}}$) of the FL lamps efficiently absorbs the emitted UV light in the positive column before the reach to the phosphor screen. This is the reason that the commercial 40W-HCFL lamps are produced with the outer diameter of $3.2 \times 10^{-2} \text{ m}$ (T-10). Anyhow we take the commercial 40W-HCFL lamps for the conversion to the coil-EEFL lamps.

Figure 31 shows four lighted coil-EEFL lamps converted from the commercial 40W-HCFL lamp. Above two FL lamps are the life-terminated 40W-HCFL lamps which have taken from the scrap yard. Below two FL lamps are new 40W-HCFL lamps from the store. The four coil-EEFL lamps in the parallel connection light up with one DC driving circuit with -2 kV to the cathode and +2 kV to the anode. Four coil-EEFL lamps

light up with the similar illuminance, indicating that the life termination of two HCFL lamps (above) is caused by the cut-off of the W-filament coils. The lighting FL lamps in Figure 31 give us direct evidence that the status of the Ar gas, Hg atoms, and phosphor screens in the FL lamps do not change in the operation of the FL lamps. The results of Figure 31 indicate us the long operation life of the coil-EEFL lamps. It should note that the coil-EE in Figure 31 do not push down to the outer glass wall by the shrinkage plastic tubes, because the experiments just make the confirmation of the lighting of the coil-EEFL lamps under the DC driving circuit. For the practical coil-EEFL lamps, the EE electrodes on the outer glass wall must tightly push down on the outer glass wall by the application of the thermally shrinking plastic tubes.



Figure 31: Photopictures of lighted 4 coil-EEFL lamps in parallel connection under the DC external driving circuit. Two FL lamps (above) are converted from life-terminated 40W-HCFL lamps taken from scrap yard. Two FL lamps (below) are converted from new 40W-HCFL lamps from store.

Figure 32 shows the photograph of the lighted coil-EEFL lamp in the out diameter at $3 \times 10^{-3} \text{ m}$ with the Ar gas pressure at $9.3 \times 10^3 \text{ Pa}$ (70 Torr). The cathode has (-2.0 kV) and anode has (+2.0 kV). Fortunately, we have obtained the CCFL lamp from a friend. You may have a difficulty with the commercial CCFL lamps in the narrow diameter for the conversion to the lighted coil-EEFL lamp. Many converted coil-EEFL lamps from the commercial CCFL lamps do not light up with the DC electric circuit. You may try the operation of the coil-EEFL lamps under the AC driving circuits with the voltages higher than 2 kV with the frequencies higher than 30 kHz. In this case, the external AC driving circuits have the AC current from the capacitor C_{phos} that are formed under the AC electric field from the EE on the outer glass wall. The capacitance of the C_{phos} does not change with the Ar gas pressures. If you take the cap electrodes as the EE, the external AC driving circuit surely has the large AC current because the bottom of the cap electrodes picks up the induced AC voltages from the capacitor C_{FL} . The $W_{\text{DC}} = 0$ is only obtained with the coil-EEFL lamps with the different diameters of the FL lamps.

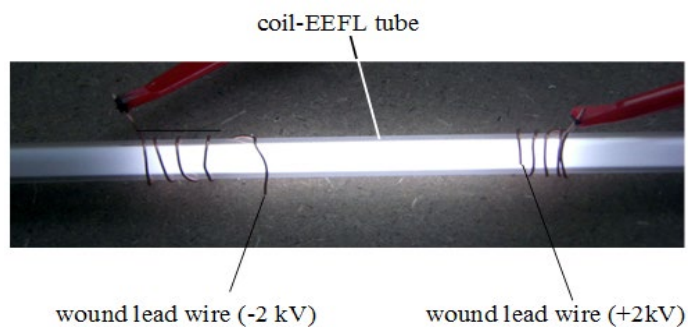

Figure 32: Photograph of lighting coil-EEFL lamp under DC (- 2 kV) and (+2 kV) to coil electrodes.

Many commercial CCFL lamps are produced with (a) the phosphor screen higher than 7 layers of the phosphor particles, (b) the rounded phosphor particles, (c) heavily contaminated surfaces of the phosphor particles as shown in Figure 28.

If you wish to make a lighted coil-EEFL lamp by the conversion from the commercial HCFL or CCFL lamps, you do not take the commercial FL lamps in the diameter less than 5×10^{-3} m (T-3) with the reason of the deep gaps between positive column and phosphor screen on the inner wall. It is a better way that you take the commercial HCFL or CCFL lamps in the outer diameters wider than 2.2×10^{-2} m (T-7). However, many commercial CCFL and HCFL lamps are produced with the unacceptable conditions for the coil-EEFL lamps [1]. Furthermore, the commercial HCFL and CCFL lamps have the heavily contaminated residual gases.

We have found another serious problem in the operation of the FL lamps under the AC driving circuit. Many commercial HCFL lamps contain the residual gases with the unacceptable level, e.g., higher than 1 Pa (around 0.01 Torr). The majorities of the residual gases are CO_2 , H_2O and air (N_2 and O_2). Under the operation of the AC driving circuit, we have found that the CH_n gases are gradually synthesized from the residual gases in the lighted Ar gas space. As the coil-EEFL lamps are operated with the AC driving circuit, the residual gases are under the periodical irradiation of the UV lights. Then the residual gases synthesize the paraffin hydrocarbons (CH_n) gases from the residual gases, mainly CO_2 , water (H_2O) and air (N_2 and O_2). The CH_n gases are polymerized with the irradiation times of the periodical irradiation of the UV lights. The surface of the polarized phosphor particles in the screen selectively adsorbs the polymerized compounds CH_n larger than $n > 4$. Then, the adsorbed CH_n compounds on the surface of the phosphor particles optically absorb the UV light from the positive column. The surface of the phosphor particles in the coil-EEFL lamps, converted from the HCFL lamps, adsorbs CH_n compounds with the operation time of

the external AC driving circuit. The phosphor screen that has the contaminated with the layers of the CH_n compounds does not emit the visible lights. We have experimentally proved the adsorption of the CH_n compounds on the phosphor particles under the EE electrodes.

Figure 33 shows the photograph of the existence of the adsorbed CH_n compounds in the lighting of the coil-EEFL lamps (three turn of coil EE) for one week under the AC driving circuit with 30 kHz. Then, the position of the coil-EEs shifts to the end of the FL tubes. The lighted EEFL lamps under the DC driving circuit clearly show the dark 3 lines that previously have had the coil-EE. The experimental results shown in Figure 33 are the direct evidence for the synthesized CH_n compounds in the lighting of the FL lamps. In the past, we have had the same trouble with the development of the color CRTs. The troubles by the residual gases removed from the color CRT and monochrome miniature CRTs by the change of the vacuum condition of the production lines. However, we have found the serious troubles with the vacuum production facilities for the production of the FL lamps. They do not accept our advices. With this reason, we cannot accept the current production facilities of the FL lamps with many laboratories and many production lines on the world, especially in Asian countries. For the production of the coil-EEFL lamps, you must use the oil-less rotary pump and periodically change the pumping oil in the diffusion pumps, hopefully each 3 months. Those troubles are not the research subject. This is the subjects for the production engineer.

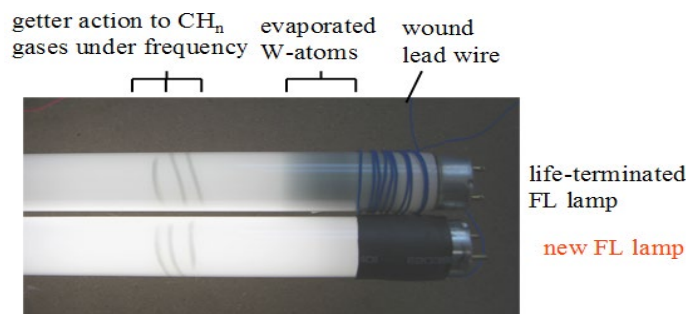

Figure 33: Getter action of coil-EEFL lamp (3 turns) under AC driving circuit (30 kHz) under the operation for one week. Coil EEFL tube above is converted from life-terminate HCFL lamp on scrap yard. The bottom coil-EEFL lamp is converted from new HCFL lamp. After one week operation, EE electrodes shift at end side of the lamps. Then the FL lamps are operated with DC driving circuits. You may see dark 3 lines that are attributable of synthesized CH_n adsorbed on phosphor screen with periodical electric field from EE.

We have found the contamination sources. At present, the inside walls of the vacuum facilities are heavily contaminated

with the old oil vapors, mainly from the rotary pump and sometimes from the diffusion pumps that have used for a long and long times. This means they never change the pumping oils from the starting day. The engineers have believed the well control of the vacuum conditions with the vacuum gages on the panel, but they do not control in the reality. If you make a FL lamp without phosphor screen and Ar gas, the vacuum sealed glass tubes brilliantly light up under the Teslar Coil. Those gases mainly synthesize CH_n gas under the periodical change of the UV lights, like as the ancient Earth. Before the study of the coil-EEFL lamps, the production engineers must solve the troubles mentioned above by them.

Conclusions

After the careful study on the fundamentals of the established HCFL lamps, we have found that the commercial HCFL lamps are produced with the premature technologies. The generation of the lights from the FL lamps starts from the moving electrons from cathode to anode at the both ends of the HCFL lamp. This is the fundamentals on the study of the FL lamps. However, we cannot find the formation of the both cathode and anode in their reports. Then, we have found the conditions of the coexistence of the cathode and anode under the AC driving circuit. The coexistence of cathode and anode at the same time is a necessary condition for moving electrons for each half cycle in the FL lamps. Under the AC driving circuit, the electrodes at both ends of the HCFL lamp never have the coexistence of positive and negative potentials for each half cycle. We cannot find the coexistence of the cathode and anode in the established reports of the FL lamps, The fundamentals are that the electrons move from the W-filament coil as the cathode at one end of the HCFL lamp to the anode at other side of the FL lamp. We have found that the formation of the volumes of corona lights that are assigned as 4th generation electron source. The HCFL lamps require the coexistence of the cathode and anode at the both ends of the FL lamp for each half cycle. Under the operation with the AC driving circuit, the HCFL lamp continuously lights up under the coexistence of the 4G cathode and anode at the both ends of the HCFL lamp. The HCFL lamp never uses the thermoelectron emission from the heated BaO particles on the W-filament coils. The heated BaO particles on the W-filament coil at other end never collect the arrived electrons from the Ar gas space. The established technologies of the HCFL lamps by the thermoelectron emission from the heated BaO particles are the false story.

We have found that the heated BaO particles at nearby the heated bear spot of the W-filament coil help the holding of the 4G cathode and anode in the lighted HCFL lamps. It can say that the BaO particles act as an important role for the holding of the 4G volumes during the unheated half cycle of the AC driving circuit. The weak point of the 4G

volumes as the cathode and anode is the short operation life at around 500 hours. The operation life of the HCFL lamps is determined by the cutoff at the heated bear spot of the W-filament coil by the evaporation of the W-atoms to the vacuum. The operation life of the HCFL lamps extends to 10^4 hours under the AC operation with the frequencies higher than 30 kHz.

As the HCFL lamps are operated with the AC driving circuit, the electrodes of the HCFL lamps solely pick up the induced voltages from the capacitor C_{FL} that is generated by the synchronously displacing electrons in the 3p_6 orbital shell of Ar^{1+} under the AC driving circuit. After the critical analysis, we have a conclusion that the HCFL lamps are produced with the premature technologies.

The analytical results described above lead us to the development of the coil-EEFL lamp. The coil-EEFL lamps form the cathode and anode of the internal DC electric circuit in the Ar gas space under the help of the electric field of the external driving circuit. There is no electron flow between the disparities of the internal and external electric circuits. Fundamentally, the lights are solely generated with the moving electrons between cathode and anode of the isolated internal DC electric circuit formed in the Ar gas space. We have found that the electrons from the cathode move on in the superconductive vacuum between Ar atoms, giving rise to the astronomical quantum efficiency, $\eta_q = 10^{13}$ visible photons $(\text{m}^3, \text{s})^{-1}$ with no power consumption of the external DC driving circuit; $W_{\text{DC}} = 0$. The coil-EEFL lamps are also operated with the external AC driving circuit with the induced electric voltages of the capacitor C_{phos} that are periodically polarized phosphor particles under the electric field from the EE on the outer glass wall. The C_{phos} does not relate with the Ar gas pressures. There is no consumption of the Ar atoms and Hg atoms in the operation of the coil-EEFL lamp, promising the operation life longer than 10^6 hours.

Here arises a difficulty for the production of the coil-EEFL lamps. For the production of the advanced coil-EEFL lamps, we cannot use the existing production facilities for the FL lamps, and commercial phosphor powders. The main reasons are: (i) The inside of the established FL production facilities are heavily contaminated with the old pumping oils. (ii) The polluted materials in the air of the working room. (iii) The FL glass tubes are a good thermal insulator, so that the existing degassing furnaces for the FL production have the inadequate temperature profiles. The heating furnaces should be uniformly heating of the entire FL glass tubes. And (iv) the trajectory of the moving electrons in the Ar gas space are severely influenced with the improper distribution of the electric charges on the phosphor screens. Those are not for the advanced research subjects. Those are the engineering subjects. In this report, we have clarified the old

established technologies. And then, we have introduced the new technologies of the FL lamps that belong to the subject of the research laboratory.

The developed coil-EEFL lamps that brilliantly light up with the $\eta_q = 10^{13}$ photons $(\text{m}^3, \text{s})^{-1}$ under the zero electric power consumption of the DC driving circuit; $W_{\text{dc}} = 0$. The coil-EEFL lamps are the unrivaled incandescent lamp over the other incandescent lamp. Especially it is the LED lamps that have only $\eta_q < 0.8$ maximum. The developed coil-EEFL lamps are the suitable incandescent light sources for the illumination of the rooms. The coil-EEFL lamps may also use the backlights of the LCD panel for the computer display and TV sets with the zero of the electric power consumption and long operation life of 10^6 hours. The developed coil-EEFL lamps may change the operation condition of the green houses in the agricultures with the combination of the solar panel and batteries. We have believed that the developed coil-EEFL lamps surely contribute to the green energy project COP (Conference of the Particles) on the world after the clarification of the applied research laboratories.

References

1. Lyuji Ozawa (2015) Coil-EEFL tube as supreme incandescent light source with zero electric power consumption, astronomical quantum efficiency, and long life. *A Physics and Space Science* 16: 16-50.
2. Machelet RR (1926) US Pat. 1,612,387.
3. Meyer F, (1928) US Pat. 2,182,732.
4. Waymouth JF (1971) *Electron Discharge Lamp*. MIT Press.
5. Flower RH, Nordheim LW (1928) Electron Emission in Intense Electric Fields. *Proc Roy Soc A* 119(781): 173-181.
6. (1973) *Handbook of Electric Discharge Lamps*. Japanese Institute of Electric Eng.
7. (2003) *Handbook of Physics and Chemistry*, CRC Press, Taylor & Francis Group, Boca Raton, London, New York.
8. Shionoya S, Yen WM (1998) *Phosphor Hand Book*, CRC Press, Taylor Francis Group, Boca Raton.
9. (1993) *The fundamental data on electrical discharge gases*, American Vacuum Society Classics, American Institute of Physics.
10. (1993) *Field emission and field ionization*, American Vacuum Society Classics, American Institute of Physics.
11. (1993) *Vacuum technology and space simulation*, American Vacuum Society Classics, American Institute of Physics.
12. (1993) *The physical basics of ultrahigh vacuum*, American Vacuum Society Classics, American Institute of Physics.
13. (1993) *Handbook of electron tube and vacuum techniques* American Vacuum Society Classics, American Institute of Physics.
14. (1993) *Vacuum sealing techniques*, American Vacuum Society Classics, American Institute of Physics.
15. (1993) *Ionized gases*, American Vacuum Society Classics, American Institute of Physics.
16. (1987) *Handbook of Physics and Chemistry*, Iwanami Publishing, Tokyo, Japan.
17. Lyuji Ozawa (1990) *Cathodoluminescence, Theory and Application*, VCH and Kodansha.
18. Lyuji Ozawa (1994) *Application of Cathodoluminescence to Display Devices*, Kodansha, Tokyo, Japan.
19. Lyuji Ozawa (2007) *Cathodoluminescence and Photoluminescence, Theories and practical application*, CRC Press, Taylor & Francis Group, Boca Raton, London, New York.
20. Lyuji Ozawa (2015) Special arrangement of phosphor particles in screen for optimization of illuminance (lm, m^{-2}) of FL tubes. *Science Research* 3(6): 261-272.
21. Lyuji Ozawa (2018) An invitation of coil-EEFL lamps operated with $W_{\text{dc}} = 0$ for a great contribution to green energy project of UN. *Open Access Journal of Physics* 11: 1-16.
22. Lyuji Ozawa (2016) Unrivalled incandescent lamp for green energy project. *World Journal of Applied Physics* 1(1): 1-15.

